

iQ700, wall-mounted cooker hood, 90 cm, clear glass black printed LC97FVW69I



- ✓ iQdrive motor - The quiet, high-performance motor ensures efficient removal of odours and steam.
- ✓ Detects steam and odours to adjust the power level automatically – climateControl sensor with cookConnect system
- ✓ Highlight your kitchen – emotionLight Pro.
- ✓ voiceControl – Control hood functions and lighting using your voice.
- ✓ Home Connect – The app that makes your hood work smarter.

Typology: Wall-mounted
 Length electrical supply cord: 130.0 cm
 Height of product, without chimney: 430 mm
 Net weight: 25.4 kg
 Type of control: Electronic
 Number of speed settings: 3-stage + 2 intensive
 Maximum output air extraction: 394 m³/h
 Boost position output recirculating: 404 m³/h
 Maximum output recirculating air: 249 m³/h
 Boost position air extraction: 717 m³/h
 Number of lights: 2
 Noise level: 57 dB(A) re 1 pW
 Diameter of air outlet: 120 / 150 mm
 Grease filter material: Other
 Odour filter: No
 Air circulation: Convertible
 Optional accessories: LZ10AF500, LZ10AXK50, LZ10AXL50, LZ11AFB16, LZ11AFI16, LZ11AFV16, LZ11AXC56, LZ11AXE61, LZ00XXP00, LZ10AFR00, LZ31XXB16
 Type of lamps used: LED
 Grease filter type: Multilayer cassette
 Connection Rating: 150 W
 Fuse protection: 10 A
 Voltage: 220-240 V
 Frequency: 50; 60 Hz
 Plug type: India plug (6 Ampere)
 Type: Wall-mounted
 Material body: Glass, Lacquered
 Plug type: India plug (6 Ampere)
 Dimensions of the product, with chimney (if exists) (in): x x
 Dimensions of the packed product: 21.25 x 29.13 x 40.94
 Net weight: 56.000 lbs
 Gross weight: 72.000 lbs
 Motor location: Integrated motor in hood body
 No-return airflow flap: Yes
 Length electrical supply cord: 130.0 cm
 Dimensions of the product, with chimney (if exists): ..500 x 890.0 x 263.0 mm
 Dimensions of the packed product (HxWxD): . 540 x 740 x 1040 mm
 Net weight: 25.4 kg
 Gross weight: 32.7 kg
 Delay Shut off modes: 10 min

LZ10AF500	Long Life recirculation kit
LZ10AXK50	Chimney extension 1000 mm
LZ10AXL50	Chimney extension 1500 mm
LZ11AFB16	Clean Air Plus odor filter (replacement)
LZ11AFI16	Clean Air Plus recirculation kit
LZ11AFV16	Clean Air Plus recirc. kit (chimless)
LZ11AXC56	Clean Air Plus recirc. kit external
LZ11AXE61	Chimney standard black
LZ00XXP00	Long Life odor filter (replacement)
LZ10AFR00	Long Life recirculation kit (chimless)
LZ31XXB16	Clean Air Plus odor filter (replacement)



iQ700, wall-mounted cooker hood, 90 cm, clear glass black printed LC97FVW69I

- LC97FVW69I

Performance

- Max. extraction rate: 717 m³/h
- Noise min./max. Normal Level: 43/57 dB
- Extraction rate according to EN 61591 ø 15 cm:
- max. Normal use: 394 m³/h
- Intensive: 717 m³/h
- Noise level according to EN 60704-3 und EN 60704-2-13 exhaust air:
- Max. normal use: 57 dB(A) re 1 pW (44 dB(A) re 20 µPa sound pressure)
- Intensive: 70 dB(A) re 1 pW (57 dB(A) re 20 µPa sound pressure)
- Extraction rate in recirculation mode:
- Max. normal use: 311 m³/h
- Intensive: 578 m³/h
- 3 speeds plus 2 intensive
- Air quality sensor

Design

- For wall mounted installation
- black Flat brand design
- Flat brand design
- 90 cm

Comfort

- PowerBoost position
- Automatic 10 minutes after running
- 2 capture areas: front side and bottom side
- Automatic revert setting, 6 minutes
- easy to clean innerframe
- Ambient light RGB
- Light dimmer function
- Softlight with dimmer function
- Efficient BLDC-technology
- 2 single inlet vertical, Efficient BLDC-technology
- 2 x 3W LED
- Light Intensity: 589 lux
- Colour Temperature: 3500 K
- Rim ventilation
- Saturation display filter: grease- and charcoal filter
- Rim extraction
- Steel filter cover, dishwasher safe
- Touch control
- Boost function
- Energy Efficiency Class: B
- Average Energy Consumption: 40 kWh/year*
- Blower Efficiency Class: B*
- Lighting Efficiency Class: A*

- Grease Filtering Efficiency Class: B*

Technical Information

- Suitable for ducted and re-circulating operation only
- In recirculation operation chimless use possible
- For recirculated extraction a recirculating kit or a CleanAir recirculation kit (accessory) is needed
- Dimensions exhaust air (HxWxD): 969-1239 x 890 x 263 mm
- Dimensions recirculating, chimney (HxWxD): 1029-1299 x 890 x 263 mm
- Dimensions recirculating with CleanAir module (HxWxD):
- 1159 x 890 x 263 mm - mounting with outer chimney
- 1229-1499 x 890 x 263 mm - mounting with telescopic chimney
- Wall fixing inclined/flat/cube
- Diameter pipe Ø 150 mm (Ø 120 mm enclosed)
- Total Connected load: 150 W
- Twin channel high performance fan motor
- Connecting cable 130 cm

Remote Monitoring and Control (only in countries where Home Connect service is available)

- Remote Monitoring and Control for connected home appliances and operation via smartphone or tablet (only in countries where Home Connect service is available)
- The Home Connect functionality can be extended by integrating numerous applications from external cooperation partners (partnerships)
- Voice Control enabled via popular voice assistants (only in countries where this service is available)
- Cooktop-based hood control
- (with matching cooktop)
- None, Cooktop-based hood control

* In accordance with the EU-Regulation No 65/2014

iQ700, wall-mounted cooker hood, 90 cm, clear glass black printed LC97FVW69I

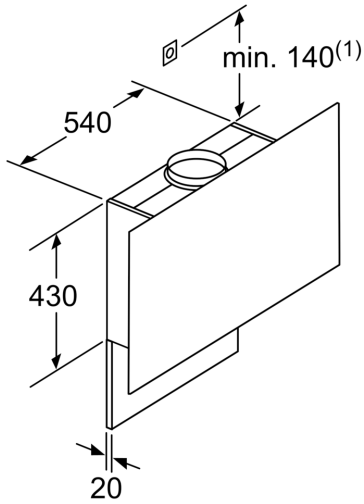

(1) Position of socket

Note the maximum thickness of the back panel.

measurements in mm

Measurements in mm

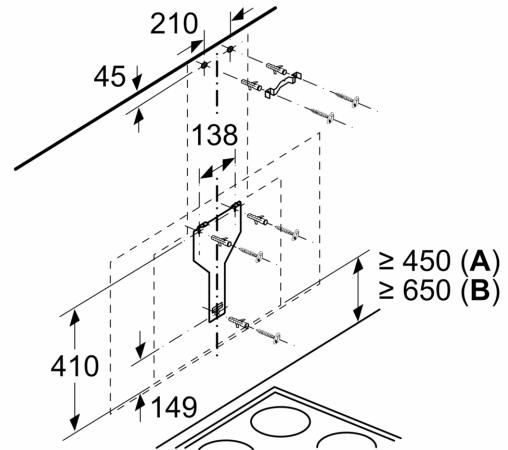

From upper edge of pan support

A: Electric
B: Gas

Measurements in mm

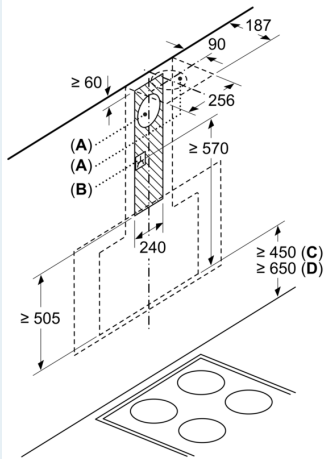

A: Exhaust air
B: Socket

From upper edge of pan support

C: Electric
D: Gas

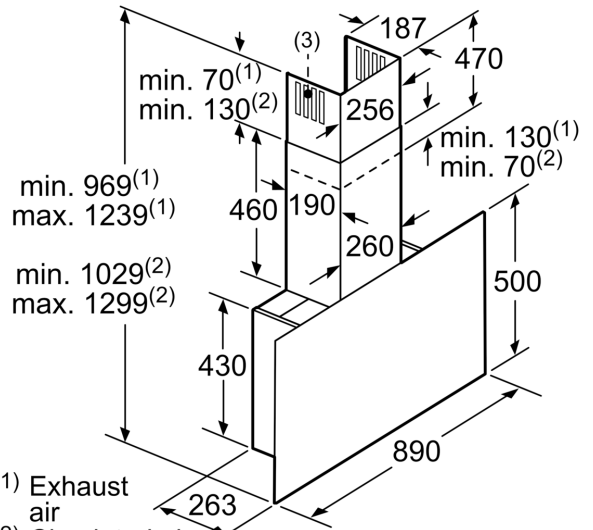

(1) Exhaust air
(2) Circulated air
(3) Air outlet – slot for exhaust air to be mounted facing down

measurements in mm

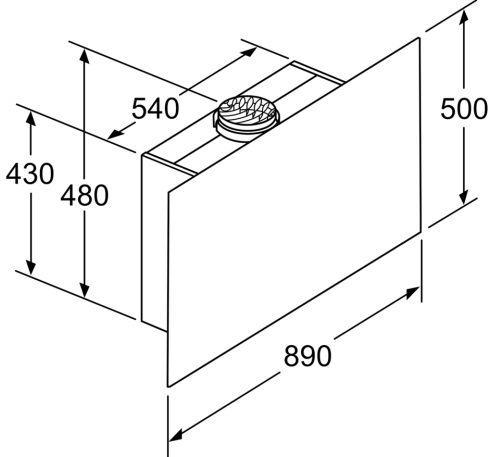

Appliance in circulated air mode
without duct
Circulated air set required
measurements in mm

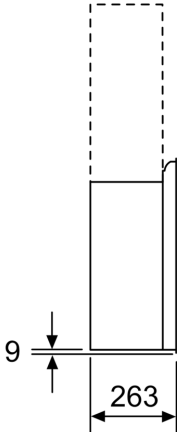

measurements in mm