

iQ500, built-in fridge-freezer with freezer at bottom, 177.2 x 55.8 cm, flat hinge KI87SAF30



iQ 500 built-in fridge freezer, with lowFrost technology and hydroFresh Box to keep produce fresh up to twice as long.

- ✓ Hyperfresh Plus: keeps fruits and vegetables fresh for up to 2 times longer.
- ✓ The bigBox offers plenty of space to store and stack large frozen items efficiently.
- ✓ The easyAccess glass shelves make loading easier and give you a better view of your food items.
- ✓ The superCooling button reduces the temperature for a set time, to quickly cool down fresh food items.
- ✓ One shelf with two separate parts to fit varying storage needs – varioShelf

Features

Technical Data

Built-in / Free-standing : Built-in
 Number of compressors : 1
 Number of independent cooling systems : 2
 Width of the appliance : 558 mm
 Depth of the product : 545 mm
 Net weight : 68.8 kg
 Required niche size for installation (HxWxD) : 1775.0 x 560 x 550 mm
 Door panel options : Not possible
 Door hinge : Right reversible
 Number of Adjustable Shelves in fridge compartment : 4
 Shelves for Bottles : No
 Frost free system : No
 Interior ventilator : No
 Reversible Door Hinge : Yes
 Length electrical supply cord : 230 cm
 Noise level : 36 dB(A) re 1 pW
 Multi-Flow Air Tower : No
 Fast cooling switch : Yes
 Fast freezing switch : No
 Temperature Controlled Drawer : No
 Humidity Control Drawer : Yes
 Number of Door Bins - Refrigerator : 4
 Door bin adjustability - Refrigerator : Yes
 Tilt-out door bins in fridge : Yes
 Gallon Storage : Yes
 Number of Gallon storage : 1
 Motorized Shelf : No
 Material of the shelves : Safety glass
 Door opened indicator freezer : No
 Drawers with telescopic rails : none
 Automatic motor-driven ice-maker : No
 Connection Rating : 90 W
 Fuse protection : 10 A
 Voltage : 220-240 V
 Frequency : 50 Hz
 Storage Period in Event of Power Failure (h) : 26 h
 Approval certificates : CE, VDE
 Main colour of product : Not applicable
 Door panel options : Not possible
 Noise level : 36 dB(A) re 1 pW
 Energy consumption annual - NEW (2010/30/EC) : 225.00 kWh/annum
 Refrigerator Net capacity - NEW (2010/30/EC) : 209 l
 Freezer Net capacity - NEW (2010/30/EC) : 61 l
 Frost free system : No
 Freezing capacity) - NEW (2010/30/EC) : 7 kg/24h
 Energy Star Qualified : No
 Approval certificates : CE, VDE
 Plug type : Gardy plug w/ earthing
 Required cutout/niche size for installation (in) : x x
 Dimensions of the packed product : 72.44 x 24.40 x 25.19
 Net weight : 152.000 lbs
 Gross weight : 163.000 lbs

Included accessories

- 2 x cold accumulator
- 2 x egg tray
- 1 x ice cube tray

**iQ500, built-in fridge-freezer with
freezer at bottom, 177.2 x 55.8 cm, flat
hinge
KI87SAF30**

Features

- Internal LED lighting in fridge Interior Light at the top
- Interior door tray design with silver trim
- Touchcontrol- Electronic - External LED electronic control

Fridge Compartment

- 5 safety glass shelves (4 height adjustable), of which Base plates, Extendable glass shelf
- 5 door bins, there of 1x dairy compartment
- freshSense - constant temperature by intelligent sensor technology
- Twin evaporators allows independent temperature control and ensures there is no transference of humidity between the fridge and freezer cavity.
- Super cool function
- Holiday mode
- Door open warning signal: Acoustic door open warning
- Malfunction warning signal: Freezer section warning function: Visual/acoustic

Freshness System

- 1 cont. hydrofresh with humidity control - keeps fruit and vegetables up to 2 x longer fresh!

Freezer Compartment

- Freezing capacity: 7 kg/ 24 h
- Cooling Retention during Power Failure: 26 h (for both Fridge and Freezer)
- Super freeze function with automatic switch off
- 2 transparent freezer drawers

Technical Information

- Net Capacity (Total) : 270 L
- Net Capacity Fridge: 209 L
- Net Capacity Freezer: 61 L
- Right hinged door, reversible door
- Connection value 90 W
- Nominal voltage: 220 - 240 V

Dimensions

- Appliance Height: 1772 mm Appliance Width: 558 mm Appliance Depth: 545 mm
- Niche Dimension (HxWxD): 177.5 cm x 56 cm x 55 cm

Accessories

General Information

**iQ500, built-in fridge-freezer with
freezer at bottom, 177.2 x 55.8 cm, flat
hinge
KI87SAF30**

Dimensioned drawings

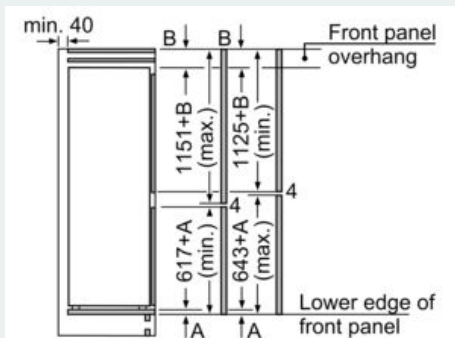
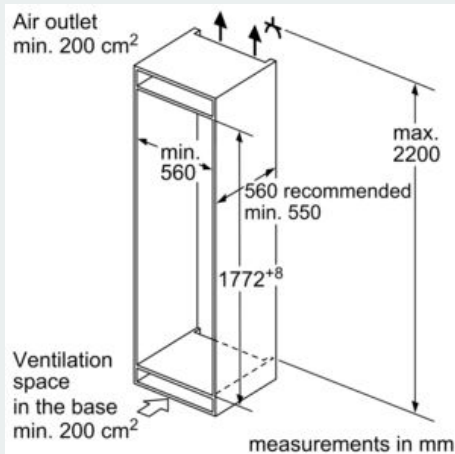
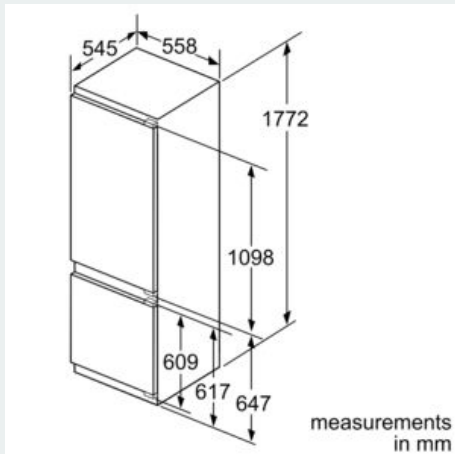

The specified unit door dimensions are valid for a door gap of 4 mm.
measurements in mm

measurements in mm
Recommended gap dimensions for flat hinges

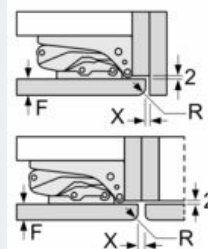

F	R	X
16-19	0-3	2.5
20	0-1	3
	2-3	2.5
21	0-1	3
	2-3	2.5
22	0	4
	1	3.5
	2-3	3

The gap dimensions recommended in the table must be adhered to in order to ensure that appliance doors do not collide with anything when they are opened, and to avoid causing damage to kitchen units.