

iQ700, 175.6 x 91.2 cm, Black
KA92NLB35I



A large capacity side-by-side fridge-freezer, Black Glass door finishing and Premium Touch Electronic control

- ✓ hyperFresh plus: Longer freshness for fruits and veggies.
- ✓ noFrost technology prevents icing and frosting so you never have to defrost again.
- ✓ More storage space for your groceries – bigCapacity.
- ✓ bigBox: Extra space for large frozen goods.
- ✓ superCooling: Fast cooling for your fresh food.

Built-in / Free-standing:	Freestanding
Number of compressors:	1
Number of independent cooling systems:	2
Width of the appliance:	912 mm
Height:	1756 mm
Depth:	732 mm
Net weight:	134.3 kg
Door panel options:	Not possible
Door hinge:	left and right
Number of Adjustable Shelves in fridge compartment:	3
Shelves for Bottles:	Yes
Frost free system:	Fridge
Interior ventilator:	No
Reversible Door Hinge:	No
Length electrical supply cord:	300.0 cm
Noise level:	43 dB(A) re 1pW
Multi-Flow Air Tower:	Yes
Fast cooling switch:	Yes
Fast freezing switch:	No
Carbon Air Filter:	No
Temperature Controlled Drawer:	No
Humidity Control Drawer:	No
Number of Door Bins - Refrigerator:	5
Door bin adjustability - Refrigerator:	No
Tilt-out door bins in fridge:	Yes
Number of Gallon storage:	2
Number of shelves - Freezer:	2
Shelf Adjustability - Freezer:	Yes
Connection Rating:	190 W
Fuse protection:	10 A
Voltage:	220-240 V
Frequency:	50-60 Hz
Storage Period in Event of Power Failure (h):	12 h
Color / Material body:	Chrome Inox-metallic
Door panel options:	Not possible
Noise level:	43 dB(A) re 1pW
Energy Star Qualified:	No
Required cutout/niche size for installation (in):	x
Dimensions of the packed product:	74.25 x 38.58 x 31.10
Net weight:	296.000 lbs
Gross weight:	324.000 lbs



iQ700, 175.6 x 91.2 cm, Black KA92NLB35I

General Data

- Gross Capacity (Total): 655 L
- Gross Capacity (Fridge): 404 L
- Gross Capacity (Freezer): 251 L
- Energy Efficiency Rating: A++
- Appliance Height: 1756 mm
- Appliance Width: 912 mm
- Appliance Depth: 732 mm
- Net Weight: 134.3

Cooling System

- NoFrost - Saves you time and effort from defrosting.
- Supercooling - Automatically brings down the temperature of the refrigerator to cool new groceries rapidly.
- Superfreezing - Automatically brings down the temperature of the freezer to keep cool new items rapidly.
- Multi-airflow system - Minimises fluctuating temperatures by ensuring optimal and uniform air circulation in the fridge.

Convenience & Safety

- LED illumination in freezer and fridge sections
- Digital LED electronic panel
- Separate temperature controls for Fridge and Freezer
- Alarm system to alert the prolonged opening of refrigerator doors
- Easy positioning and handling with appliance on 4 wheels
- Adjustable front feet for added stability
- AirFresh Filter - Removes and prevents food odors

Fridge Compartment

- 1 hyperFresh plus box keeps food fresh for up to twice as long
- 1 hyperFresh box so fish and meat stay fresh for longer.
- 1 Fresh box for extra storage
- 3 Extension rail systems for easy pull-out of drawer-compartments
- 4 Safety Glass Shelves of which 3 are height adjustable and extendable
- 1 Dairy compartment
- 2 door trays (large)
- 3 door trays (small)

Freezer Compartment

- 2 pull out drawers, incl. 1 Big Box for large size storing
- 2 storage drawers on extension rail systems for easy pull-out
- 4 glass shelves which are 2 are adjustable
- 5 Door Bins
- Easy twist ice box
- Freezing capacity: 12 kg/ 24 h

Design and Styling

- Sleek Black glass door finishing

Accessories

- 2 x cold accumulator(s)
- 2 x egg tray(s)

iQ700, 175.6 x 91.2 cm, Black
KA92NLB35I

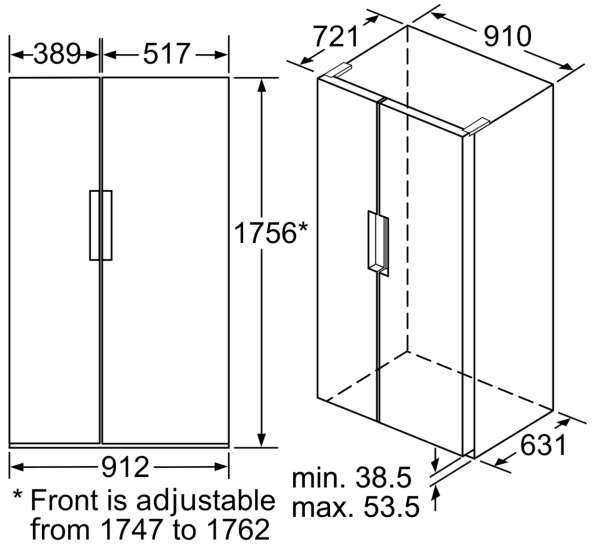

measurements in mm

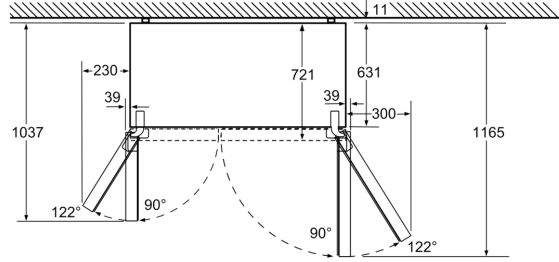

Chilling drawers can be pulled out completely at a door opening angle of 122°
measurements in mm

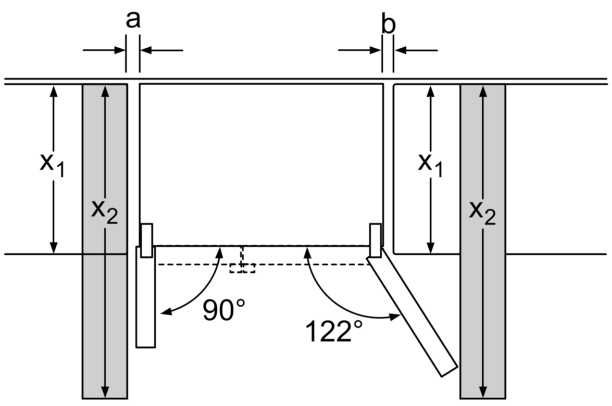

x ₁ (unit depth)	a	b
600	39	39
650	39	53
700	39	85
x ₂ (wall)	39	300

measurements in mm