

iQ700, American side by side, glass door, 175.6 x 91.2 cm, Black KA92DSB30I

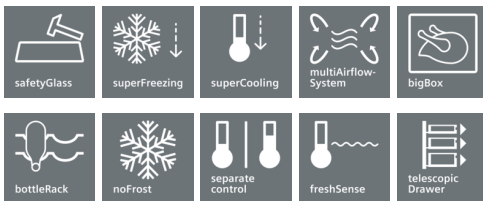

A++



A large capacity Side-by-Side fridge-freezer with Hyperfresh Plus, and ice and water dispenser with LED illumination. The Premium Touch panel provides you absolute control of your fridge with ease

- ✓ Ice and water dispenser: dispenses cool water and ice cubes at the push of a button
- ✓ Hyperfresh Plus: keeps fruits and vegetables fresh for up to 2 times longer.
- ✓ Design: Accentuated with modern sleek Black glass doors
- ✓ Premium Touch Electronic Panel: Control and set the temperature of the refrigerator with a touch of a button
- ✓ NoFrost: Prevents ice from forming, thus, saving you time and effort from defrosting.

Features

Technical Data

Built-in / Free-standing : Freestanding
 Number of compressors : 1
 Number of independent cooling systems : 2
 Width of the product (mm) : 912
 Height (mm) : 1756
 Depth of the product : 732
 Net weight (kg) : 169.765
 Door panel options : Not possible
 Door hinge : left and right
 Number of Adjustable Shelves in fridge compartment : 3
 Shelves for Bottles : Yes
 Frost free system : Fridge and freezer
 Reversible Door Hinge : No
 Length electrical supply cord (cm) : 240
 Noise level (dB) : 42
 Multi-Flow Air Tower : Yes
 Fast cooling switch : Yes
 Fast freezing switch : Yes
 Carbon Air Filter : No
 Temperature Controlled Drawer : No
 Number of Door Bins - Refrigerator : 5
 Door bin adjustability - Refrigerator : No
 Tilt-out door bins in fridge : Yes
 Number of Gallon storage : 2
 No. of shelves in fridge : 4
 Number of shelves - Freezer : 2
 Shelf Adjustability - Freezer : Yes
 Capacity of Water Tank [l] : 1.0
 Connection Rating (W) : 190
 Current (A) : 10
 Voltage (V) : 220-240
 Frequency (Hz) : 50-60
 Storage Period in Event of Power Failure (h) : 12
 Approval certificates : CE, VDE
 Color / Material body : Chrome Inox-metallic
 Door panel options : Not possible
 Noise level (dB) : 42
 Required cutout/niche size for installation (in) : x x
 Dimensions of the packed product (in) : 74.25 x 38.58 x 32.87
 Net weight (lbs) : 374
 Gross weight (lbs) : 390
 Product name / Commercial code : KA92DSB30I

Included accessories

- 2 x cold accumulator
- 1 x connection hose
- 1 x egg tray



4 242003 857243

iQ700, American side by side, glass door, 175.6 x 91.2 cm, Black KA92DSB30I

Features

General Data

- Gross Capacity (Total): 636 L
- Gross Capacity (Fridge): 404 L
- Gross Capacity (Freezer): 232 L
- Energy Efficiency Rating: A++
- Energy Consumption: 348 kWh/annum
- Appliance Height: 1,756 mm
- Appliance Width: 912 mm
- Appliance Depth: 732 mm
- Net Weight: 169.8 kg

Cooling System

- NoFrost - Saves you time and effort from defrosting.
- Supercooling - Automatically brings down the temperature of the refrigerator to cool new groceries rapidly.
- Superfreezing - Automatically brings down the temperature of the freezer to keep cool new items rapidly.
- Multi-airflow system system - Minimises fluctuating temperatures by ensuring optimal and uniform air circulation in the fridge.

Convenience & Safety

- LED illumination in fridge and freezer sections and ice-water dispenser
- Premium Touch Electronic Panel to set temperature and features of your refrigerator
- Separate temperature controls for Fridge and Freezer
-
- Alarm system to alert the prolonged opening of refrigerator doors
- Easy positioning and handling with appliance on 4 wheels
- Adjustable front feet for added stability
- NoFrost - Saves you time and effort from defrosting.

Fridge Compartment

- 1 hyperFresh plus box keeps food fresh for up to twice as long
- 1 hyperFresh box so fish and meat stay fresh for longer.
- 1 Fresh box for extra storage
- 3 Extension rail systems for easy pull-out of drawer-compartments
- 4 Safety Glass Shelves of which 3 are height adjustable and extendable
- 1 Dairy compartment
- 2 door trays (large)
- 3 door trays (small)
-
-

Freezer Compartment

- Automatic Ice-Water dispenser which dispenses water, ice-cubes and crushed-ice
- 2 drawers, of which 1 is bigbox, capable of storing large-sized packaging
- 2 storage drawers on extension rail systems for easy pull-out
- 3 glass shelves which are 2 are adjustable
- 4 door trays
- Freezing capacity: 12 kg/ 24 h

Design and Styling

- Sleek Black glass door finishing
- Aluminium vertical handle

Accessories

- 2 x cold accumulator(s)
- 1 x connection hose
- 2 x egg tray(s)

iQ700, American side by side, glass door, 175.6 x 91.2 cm, Black KA92DSB30I

Dimensioned drawings

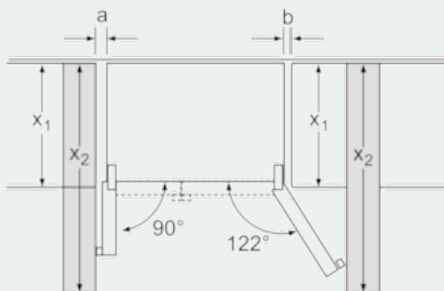
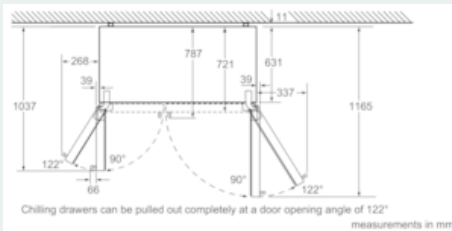
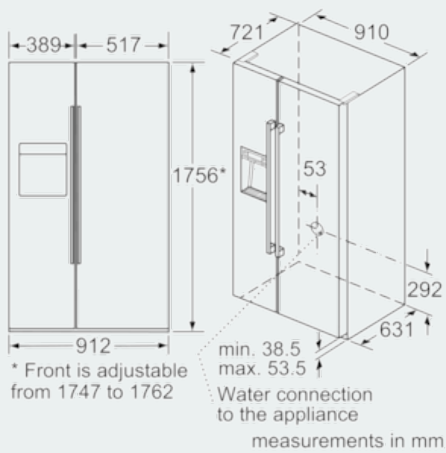

| X ₁ (unit depth) | a | b |
|-----------------------------|-----|-----|
| 600 | 39 | 39 |
| 650 | 39 | 53 |
| 700 | 39 | 85 |
| X ₂ (wall) | 105 | 337 |

measurements in mm