

**iQ500, Built-In Microwave Oven,  
59 x 38 cm, Stainless steel  
HF22G564IN**

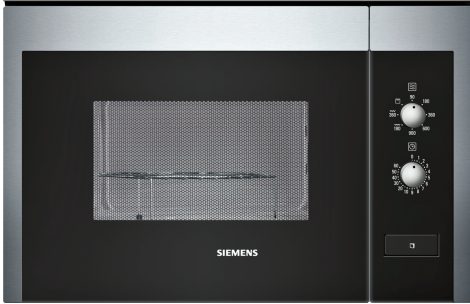

HZ86D000 Steamer Cooker Accessory for Microwave

38 cm high built-in microwave for energy-saving defrosting, reheating or preparation of dishes in the shortest possible time.

- ✓ Control elements: Rotary knob
- ✓ Left hinged door
- ✓ Oven capacity: 25 litres
- ✓ Microwave Power levels (5 levels): 900 W, 600W, 360W, 180W, 90W
- ✓ Grill 1.2 KW

Type of micro-wave oven: ..... Grill function  
 Type of control: ..... mechanical  
 Dimensions: ..... 382 x 594 x 388 mm  
 Cavity dimensions: ..... 208.0 x 328.0 x 369.0 mm  
 Length electrical supply cord: ..... 200.0 cm  
 Net weight: ..... 18.2 kg  
 Gross weight: ..... 20.7 kg  
 Maximum microwave power: ..... 900 W  
 Number of Power Levels: ..... 5  
 Turntable: ..... Yes  
 Cavity material: ..... Stainless steel  
 Door opening: ..... Button  
 Clock: ..... No  
 Height of the appliance: ..... 382 mm  
 Width of the appliance: ..... 594 mm  
 Depth: ..... 388 mm  
 Maximum microwave power: ..... 900 W  
 Connection Rating: ..... 1450 W  
 Fuse protection: ..... 10 A  
 Voltage: ..... 220-230 V  
 Frequency: ..... 50 Hz  
 Plug type: ..... India plug (16 Ampere)  
 Required cutout/niche size for installation (in): ..... x  
 Dimensions of the packed product: ..... 17.55 x 17.75 x 25.74  
 Net weight: ..... 40.000 lbs  
 Gross weight: ..... 46.000 lbs



## iQ500, Built-In Microwave Oven, 59 x 38 cm, Stainless steel HF22G564IN

### Design:

- Control elements: Rotary knob
- Left hinged door

### Heating modes

- Oven capacity: 25 litres
- Microwave Power levels (5 levels): 900 W, 600W, 360W, 180W, 90W
- Grill 1.2 KW
- Combination of Grill and Microwave power levels 360/180/90 W
- Max. time setting (MW): 60 min
- Glass Turntable diameter 31.5 cm

### Dimensions:

- Appliance dimensions (H x W x D): 38.2 cm x 59.4 cm x 38.8 cm
- Connecting cable 200 cm
- Total connected load: 1.45 KW

**iQ500, Built-In Microwave Oven,  
59 x 38 cm, Stainless steel  
HF22G564IN**

Microwave,  
corner installation

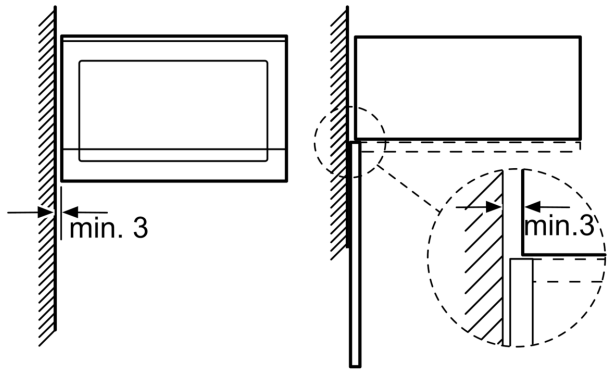

Measurements in mm

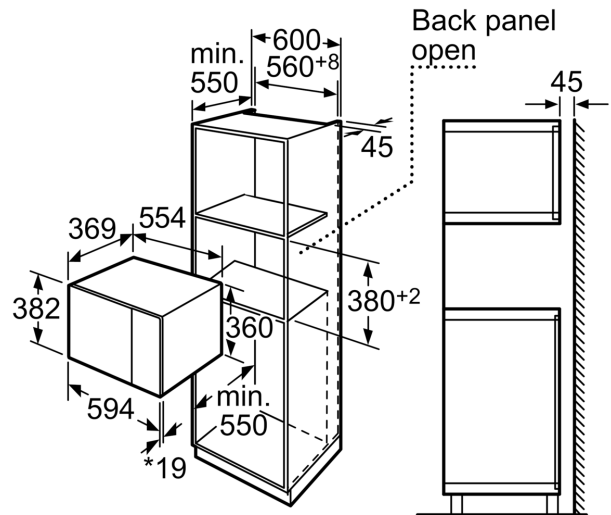

\* 20 mm for metal fascias

measurements in mm

Ventilation opening  
min. 250 cm<sup>2</sup>

Back panel  
open

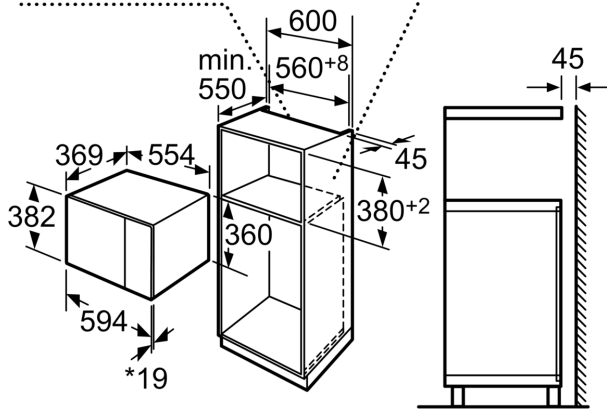

\* 20 mm for metal fascias

measurements in mm