

iQ500
HB23AB523K
60 cm Stainless steel Electric built-in oven



60 cm high built-in oven with innovative 3D hotAir Plus for perfect baking results on one, two or three baking sheets simultaneously.

- ✓ Perfect baking results on up to 3 baking sheets thanks to innovative heat distribution with 3D hotAir Plus.
- ✓ State-of-the-art, with an electronic clock including a timer for perfect timing when cooking.
- ✓ Special ecoClean coating reduces soiling and odours.
- ✓ Energy efficiency class A: For efficient roasting and baking.

Features

Technical Data

Color / Material Front : Stainless steel
 Built-in / Free-standing : Built-in
 Integrated Cleaning system : No
 Dimensions of the product (mm) : 595 x 595 x 548
 Dimensions of the packed product (HxWxD) (mm) : 660 x 690 x 660
 Control Panel Material : Stainless steel
 Door Material : Glass
 Net weight (kg) : 34.906
 Usable volume of cavity (l) : 66
 Cooking method : Bottom heat, Conventional heat, Full width variable grill, Hot Air, Hot air grilling
 First cavity material : Enameled
 Number of interior lights : 1
 Approval certificates : CE, VDE
 Length electrical supply cord (cm) : 140
 Interior Lights - cavity 1 : 1
 Pull-out system : Accessory
 Clock function : Alarm, Off, On
 Included accessories cavity 1 : 1 x enamel baking tray, 1 x combination grid, 1 x universal pan
 Broil Element Wattages cavity 1 (W) : 2800
 Energy consumption per cycle conventional (2010/30/EC) : 0.93
 Energy consumption per cycle forced air convection (2010/30/EC) : 0.84
 Energy efficiency index (2010/30/EC) : 101.2
 Electrical connection rating (W) : 3000
 Current (A) : 16
 Voltage (V) : 220-240
 Frequency (Hz) : 60; 50
 Color / Material Front : Stainless steel
 Energy input : Electric
 Approval certificates : CE, VDE
 Required cutout/niche size for installation (in) : x x
 Dimensions of the packed product (in) : 25.98 x 25.98 x 27.16
 Net weight (lbs) : 77.000
 Gross weight (lbs) : 82
 Length electrical supply cord (cm) : 140
 Net weight (kg) : 34.906
 Gross weight (kg) : 37.0

Included accessories

- 1 x enamel baking tray
- 1 x combination grid
- 1 x universal pan



iQ500**HB23AB523K****60 cm Stainless steel Electric built-in oven****Features****Design:**

- Full-glass inner door
- White display with blue indicator lights
- Drop down door

Features:

- Cavity volume: 66 l
- Multifunction oven (5 cooking functions): conventional heat, hot air plus, bottom heat, hot air grilling, full width variable grill
- Integral cooling fan
- Electronic clock timer
- Hot air temperature max.: 270 °C
- Rear panel with Ecoclean
- Grill element: Drop down grill
- Illumination type: Round light
- Number of glass panes: 3 PC
- Rapid heating-up: automatic
- Grey enamel smooth oven interior
- Triple glass touch Door temperature: 40 °C
- Safety functions: childproof lock

Dimensions:

- Appliance dimensions (H x W x D): 59.5 cm x 59.5 cm x 54.8 cm
- Cutout Dimensions (H x W x D): 57.5 - 59.7cm x 56 cm x 55 cm

Connecting cable: 95 cm**Total connected load: 3 KW**

iQ500
HB23AB523K
60 cm Stainless steel Electric built-in
oven

Dimensioned drawings

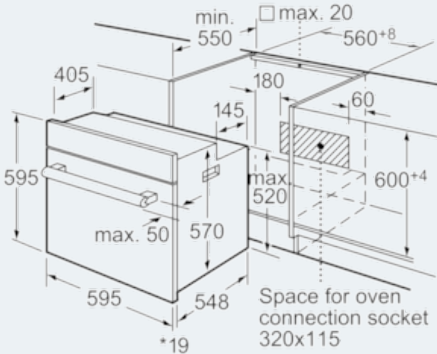

* 20 mm for metal fascias

Measurements in mm

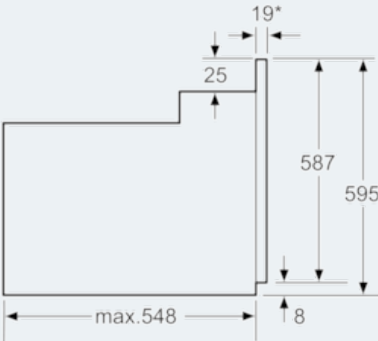

* 20 mm for metal fascias

Dimensions in mm