

iQ500, built-under freezer, 82 x 59.8 cm GU15DA55



iQ 500 undercounter freezer with 3 handy transparent freezer drawers and SuperFreezing for freezing foods faster, plus SoftClosing door.

Features

Technical Data

Product category : Upright freezer
 Built-in / Free-standing : Built-in
 Frost free system : No
 Climate class : SN-ST
 Door panel options : Possible but accessory
 Width of the appliance : 598
 Depth of the product : 548
 Dimensions of the packed product (HxWxD) (mm) : 890 x 620 x 670
 Warning signal / malfunction : visual and audible
 Defrost process : manual
 Cover door installation system : Fixed-mounted
 Number of drawers/baskets (Stck) : 3
 Number of freezing flaps (Stck) : 0
 Lockable door : No
 Thermometer freeze section : Analog
 Light : No
 Length electrical supply cord (cm) : 230
 Door hinge : Right reversible
 Net weight (kg) : 35.691
 Gross weight (kg) : 38.6
 Multi-Flow Air Tower : No
 Number of compressors : 1
 Number of independent cooling systems : 1
 Economy setting : No
 Fast freezing switch : No
 Door bin adjustability - Freezer : No
 Tilt-out door bins in freezer : No
 Door bin adjustability - Freezer : No
 Reversible Door Hinge : Yes
 Connection Rating (W) : 90
 Fuse protection (A) : 10
 Frequency (Hz) : 50
 Approval certificates : CE, Morocco, VDE
 Energy consumption annual (kWh/annum) - NEW (2010/30/EC) : 184.00
 Freezer Net capacity (l) - NEW (2010/30/EC) : 98
 Frost free system : No
 Freezing capacity (kg/24h) - NEW (2010/30/EC) : 12
 Main colour of product : Not applicable
 Door panel options : Possible but accessory
 Installation typology : Build-under
 Noise level (dB) : 38
 Energy Star Qualified : No
 Approval certificates : CE, Morocco, VDE
 Plug type : Gardy plug w/ earthing
 Required cutout/niche size for installation (in) : x x
 Dimensions of the packed product (in) : 35.03 x 26.37 x 24.40
 Net weight (lbs) : 79.000
 Gross weight (lbs) : 85.000

Included accessories

2 x cold accumulator
 1 x ice cube tray



**iQ500, built-under freezer, 82 x 59.8
cm
GU15DA55**

Features

- Net Capacity Freezer: 98 L
- Cooling Retention during Power Failure: 23 h (for both Fridge and Freezer)
- Freezing capacity: 12 kg/ 24 h

Design and Styling

- Combined to Fridge/Freezer combination
- Super freeze function
- Malfunction warning signal: optical, acoustic alarm system

Freezer Compartment

- 3 transparent freezer drawers
- Calendar frozen food

Technical Information

- Right hinged door, reversible door

Dimensions

- Appliance Height: 820 mm
- Appliance Width: 598 mm
- Appliance Depth: 548 mm
- Connection value 90 W
- Nominal voltage: 220 - 240 V

Accessories

**iQ500, built-under freezer, 82 x 59.8
cm
GU15DA55**

Dimensioned drawings

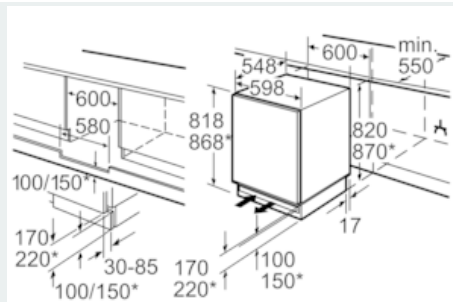

* variable base/substructure height

Space for electrical connection next to the
appliance on the left or right-hand side.
Ventilation space in the base.

measurements in mm