

**iQ500, built-in freezer, 177.2 x 55.8 cm, flat hinge  
GI81NAE31I**



noFrost technology prevents icing and frosting so you never have to defrost again.

✓ noFrost technology prevents icing and frosting so you never have to defrost again.

Type: ..... Upright freezer  
 Built-in / Free-standing: ..... Built-in  
 Frost free system: ..... Fridge and freezer  
 Climate class: ..... SN-T  
 Door panel options: ..... Not possible  
 Width of the appliance: ..... 558 mm  
 Depth: ..... 545 mm  
 Dimensions of the packed product (HxWxD): . 1840 x 610 x 640 mm  
 Warning signal / malfunction: ..... Both visual and audible  
 Cover door installation system: ..... Fixed-mounted  
 Number of drawers/baskets (Stck): ..... 5  
 Number of freezing flaps (Stck): ..... 2  
 Lockable door: ..... No  
 Thermometer freeze section: ..... Digital  
 Light: ..... No  
 Length electrical supply cord: ..... 230.0 cm  
 Door hinge: ..... Left reversible  
 Net weight: ..... 65.5 kg  
 Gross weight: ..... 70.2 kg  
 Multi-Flow Air Tower: ..... No  
 Number of compressors: ..... 1  
 Number of independent cooling systems: ..... 1  
 Economy setting: ..... No  
 Fast freezing switch: ..... No  
 Door bin adjustability - Freezer: ..... No  
 Tilt-out door bins in freezer: ..... No  
 Number of shelves - Freezer: ..... 0  
 Door bin adjustability - Freezer: ..... No  
 Shelf Material - Freezer: ..... Safety glass  
 Reversible Door Hinge: ..... Yes  
 Connection Rating: ..... 120 W  
 Fuse protection: ..... 6 A  
 Frequency: ..... 50 Hz  
 Door panel options: ..... Not possible  
 Type: ..... Full-integrated  
 Noise level: ..... 36 dB(A) re 1 pW  
 Energy Star Qualified: ..... No  
 Plug type: ..... India plug (6 Ampere)  
 Required cutout/niche size for installation (in): ..... x  
 Dimensions of the packed product: ..... 72.44 x 24.01 x 25.19  
 Net weight: ..... 144.000 lbs  
 Gross weight: ..... 155.000 lbs  
 Included accessories: ..... 2 x cold accumulator, 1 x ice cube tray



## iQ500, built-in freezer, 177.2 x 55.8 cm, flat hinge GI81NAE31I

### General Data

- Gross Capacity (Total): 235 L
- Net Capacity (Total): 212L
- Net Capacity (Freezer): 212L
- Appliance Height: 1772 mm
- Appliance Width:558 mm
- Appliance Depth:545 mm

### Cooling System

- NoFrost - Saves you time and effort from defrosting.
- Superfreezing - Automatically brings down the temperature of the freezer to keep cool new items rapidly.

### Freezer Compartment

- 7 Pull-out drawers, including 2 Big Box for storing large items
- Freezing capacity: 13.8 kg/ 24 h

### Accessories

- 2 x cold accumulator(s)
- 1 x ice cube tray(s)

iQ500, built-in freezer, 177.2 x 55.8 cm, flat hinge  
GI81NAE31I

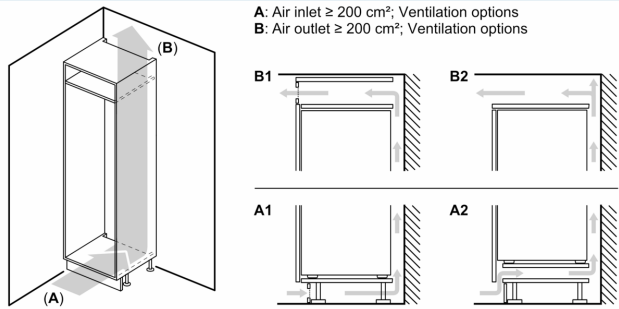

**Maximal permissible weight of the unit fronts**

Fitted unit fronts that exceed the permissible weight may cause damage and result in functional impairment of the hinges

**Δ** Weight  
A: Appliance door height including hinges in mm  
B: Undamped hinge, unit front in kg  
C: Damped hinge, unit front in kg  
D: Additional possible load in kg with heavy load kit

A	B	C	D
1500-1750	22	22	B+5 / C+5
720-1400	19	19	
A1	15	19	
A2	15	19	

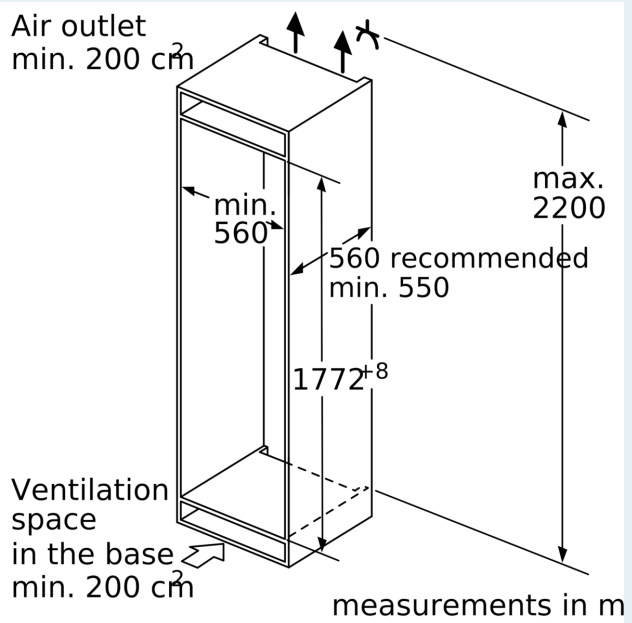
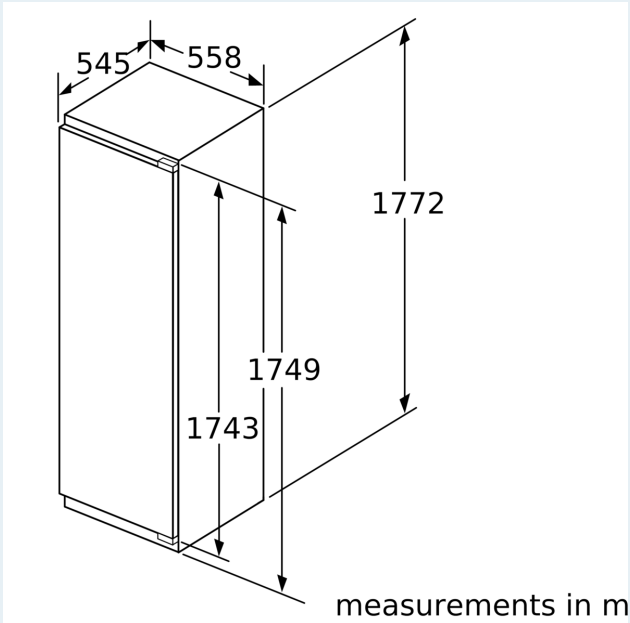

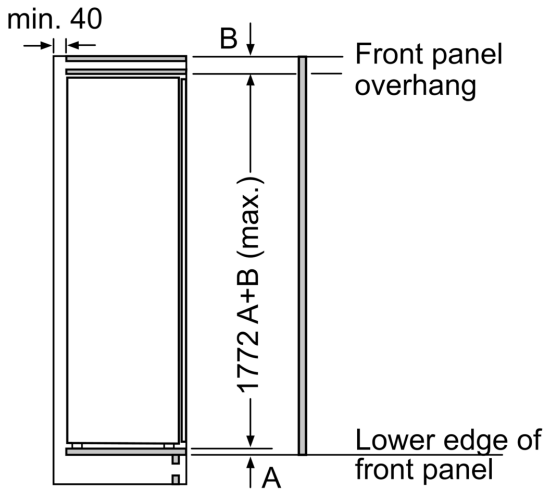

measurements in mm

Maximal permissible weight of the unit fronts

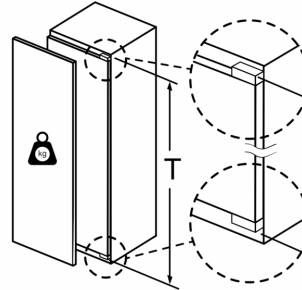

Fitted kitchen unit doors that exceed the permissible weight may cause damage and result in functional impairment of the hinges.

T: Includes height of appliance door Hinges in mm:	undamped hinge, Door in kg:	damped hinge, Door in kg:
1500-1750	22	22

measurements in mm  
Recommended gap dimensions for flat hinges

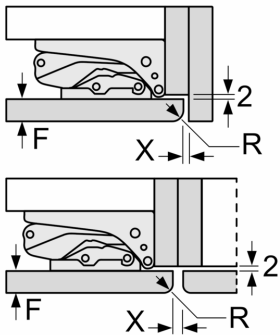

F	R	X
16-19	0-3	2.5
20	0-1	3
	2-3	2.5
21	0-1	3
	2-3	2.5
22	0	4
	1	3.5
	2-3	3

The gap dimensions recommended in the table must be adhered to in order to ensure that appliance doors do not collide with anything when they are opened, and to avoid causing damage to kitchen units.