

## iQ500, built-in freezer, 177.2 x 55.8 cm GI81NAE30



noFrost technology prevents icing and frosting so you never have to defrost again.

- ✓ noFrost technology prevents icing and frosting so you never have to defrost again.
- ✓ NoFrost: Prevents ice from forming, thus, saving you time and effort from defrosting.

### Features

#### Technical Data

Product category : Upright freezer  
 Built-in / Free-standing : Built-in  
 Frost free system : Fridge and freezer  
 Climate class : SN-T  
 Door panel options : Not possible  
 Width of the appliance : 558  
 Depth of the product : 545  
 Dimensions of the packed product (HxWxD) (mm) : 1840 x 640 x 620  
 Warning signal / malfunction : visual and audible  
 Cover door installation system : Fixed-mounted  
 Number of drawers/baskets (Stck) : 5  
 Number of freezing flaps (Stck) : 2  
 Lockable door : No  
 Thermometer freeze section : Digital  
 Light : No  
 Length electrical supply cord (cm) : 230  
 Door hinge : Left reversible  
 Net weight (kg) : 68.206  
 Gross weight (kg) : 73.4  
 Multi-Flow Air Tower : No  
 Number of compressors : 1  
 Number of independent cooling systems : 1  
 Economy setting : No  
 Fast freezing switch : No  
 Door bin adjustability - Freezer : No  
 Tilt-out door bins in freezer : No  
 Number of shelves - Freezer : 0  
 Door bin adjustability - Freezer : No  
 Shelf Material - Freezer : Safety glass  
 Reversible Door Hinge : Yes  
 Connection Rating (W) : 120  
 Fuse protection (A) : 10  
 Frequency (Hz) : 50  
 Approval certificates : CE, VDE  
 Energy consumption annual (kWh/annum) - NEW (2010/30/EC) : 243.00  
 Freezer Net capacity (l) - NEW (2010/30/EC) : 211  
 Frost free system : Fridge and freezer  
 Freezing capacity (kg/24h) - NEW (2010/30/EC) : 20  
 Main colour of product : Not applicable  
 Door panel options : Not possible  
 Installation typology : Full-integrated  
 Noise level (dB) : 36  
 Energy Star Qualified : No  
 Approval certificates : CE, VDE  
 Plug type : Gardy plug w/ earthing  
 Required cutout/niche size for installation (in) : x x  
 Dimensions of the packed product (in) : 72.44 x 24.40 x 25.19  
 Net weight (lbs) : 150.000  
 Gross weight (lbs) : 162.000

### Included accessories

- 2 x cold accumulator
- 1 x ice cube tray



## iQ500, built-in freezer, 177.2 x 55.8 cm GI81NAE30

### Features

#### General Data

- Gross Capacity (Total): 235 L
- Net Capacity (Total): 211L
- Net Capacity (Freezer): 211L
- Appliance Height: 1772 mm
- Appliance Width: 558 mm
- Appliance Depth: 545 mm

#### Cooling System

- NoFrost - Saves you time and effort from defrosting.
- Superfreezing - Automatically brings down the temperature of the freezer to keep cool new items rapidly.

#### Freezer Compartment

- 7 Pull-out drawers, including 2 Big Box for storing large items
- Freezing capacity: 20 kg/ 24 h

#### Accessories

- 2 x cold accumulator(s)
- 1 x ice cube tray(s)
-

iQ500, built-in freezer, 177.2 x 55.8 cm  
GI81NAE30

Dimensioned drawings

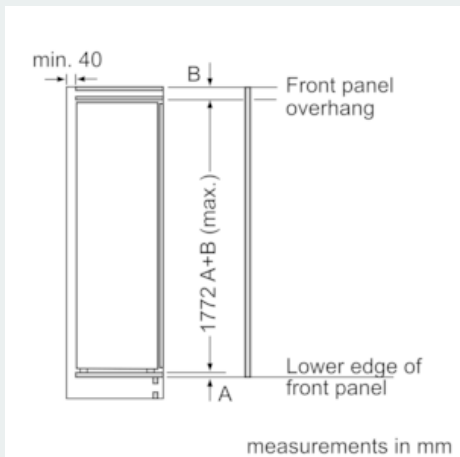
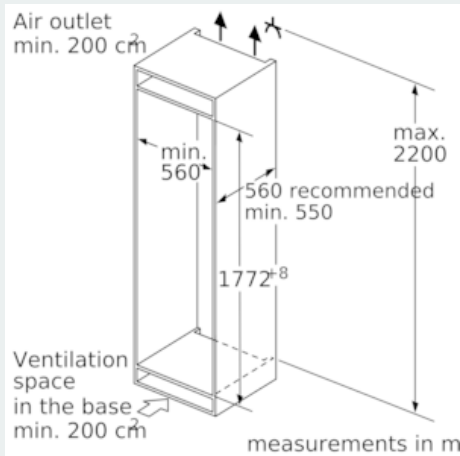
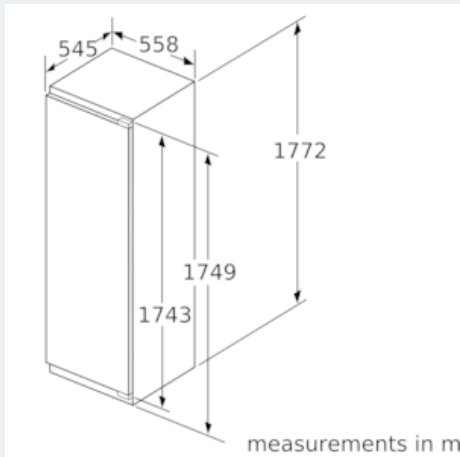

Maximal permissible weight of the unit fronts

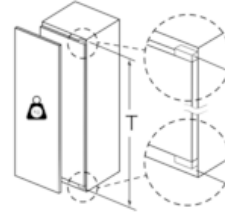

Fitted kitchen unit doors that exceed the permissible weight may cause damage and result in functional impairment of the hinges.

T: Includes height of appliance door Hinges in mm:	undamped hinge, Door in kg:	damped hinge, Door in kg:
1500-1750	22	22

measurements in mm

Recommended gap dimensions for flat hinges

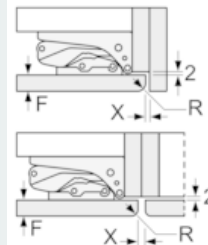

F	R	X
16-19	0-3	2.5
20	0-1	3
	2-3	2.5
21	0-1	3
	2-3	2.5
22	0	4
	1	3.5
	2-3	3

The gap dimensions recommended in the table must be adhered to in order to ensure that appliance doors do not collide with anything when they are opened, and to avoid causing damage to kitchen units.