

**iQ700, Induction hob with integrated ventilation system, 80 cm, surface mount with frame EX875LX34E**

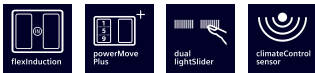

HZ381401 Exhaust kit, HZ381501 Recirculating kit, HZ381700 Recirculation filter, HZ390011 Stainless Steel roaster with glass lid, HZ390012 Steaming Rack for Stainless Steel roaster, HZ390090 Wok Set consisting of 3 Items, HZ390210 System pan diameter 15 cm, HZ390220 System pan diameter 19 cm, HZ390230 System pan diameter 21cm, HZ39050 Wireless temperature sensor for cooktop, HZ390511 Teppan Yaki (small), HZ390512 Teppan Yaki (large), HZ390522 Griddle Plate, HZ394301 Connecting strip, HZ9SE030 Set of 2 pots and 1 pan

**Induction cooktop with integrated downdraft ventilation unit**

- ✓ flexInduction adapts the cooking zones to different cookware and pots up to 24 cm diameter – for more flexibility.
- ✓ powerMove Plus enables intuitive control thanks to three heating zones with different temperatures – activated by touch.
- ✓ Dual lightSlider lets you easily and intuitively operate the hob.
- ✓ The climateControl Sensor monitors steam and odors and adjusts the power level automatically.
- ✓ For more energy efficient cooking - energy consumption display.

**Product specifications**

Product name/family: ..... Cooking zone ceramic  
 Built-in / Free-standing: ..... Built-in  
 Energy input: ..... Electric  
 Total number of positions that can be used at the same time: 4  
 Required niche size for installation (HxWxD): ..... 198 x 780-780 x 490-500 mm  
 Width of the appliance: ..... 812 mm  
 Dimensions: ..... 198x812x520 mm  
 Dimensions of the packed product (HxWxD): ... 330 x 760 x 940 mm  
 Net weight: ..... 27.1 kg  
 Gross weight: ..... 33.4 kg  
 Residual heat indicator: ..... Separate  
 Location of control panel: ..... Front  
 Basic surface material: ..... Ceramic  
 Color of surface: ..... Black, Alu, brushed  
 Length electrical supply cord: ..... 110.0 cm  
 Sealed Burners: ..... No  
 Heating with booster: ..... All  
 Power of 2nd heating element (kW): ..... 3.3 kW  
 Number of speed settings: ..... 9-stage + intensive  
 Maximum output air extraction: ..... 551 m³/h  
 Boost position output recirculating: ..... 630.0 m³/h  
 Maximum output recirculating air: ..... 557 m³/h  
 Boost position air extraction: ..... 698 m³/h  
 Noise level: ..... 70 dB(A) re 1pW  
 Odour filter: ..... No  
 Air circulation: ..... Convertible  
 Grease filter type: ..... Multilayer cassette  
 Clean filter reminders: ..... Yes  
 Voltage: ..... 220-240 V  
 Frequency: ..... 60; 50 Hz



## iQ700, Induction hob with integrated ventilation system, 80 cm, surface mount with frame EX875LX34E

### Power and size

- 4 induction cooking zones
- 2 Flex zones
- 5 frying levels: Frying with integrated sensor for All Flex zones
- 17 power levels

### Design

- Stainless steel faceted design with front facette and side profiles
- Dual LightSlider

### Comfort

- Timer with switch-off function for all zones, count-up timer, per cooktop, Count down function
- 3-steps
- QuickStart Function
- Boost function for all zones
- Automatic pan recognition
- power management function Automatic safety switch off Safety lock Wipe protection function
- Main switch

### Integrated ventilation system

- Induction/Ventilation Cooktop, Autarkic
- Extraction rate according to EN 61591:
  - min. Normal use 169 m<sup>3</sup>/h
  - max. Normal use 551 m<sup>3</sup>/h
  - Intensive setting 698 m<sup>3</sup>/h
- Performance in re-circulated extraction:
  - min. normal setting 139 m<sup>3</sup>/h
  - max. normal setting 557 m<sup>3</sup>/h
  - Boost-/Intensive setting 630 m<sup>3</sup>/h
- Noise min./max. normal setting (ducted extraction): 42/70 db(A)
- 9 fan speed levels plus 1 intensive setting
- Suitable for ducted or re-circulated extraction (Accessory is required)
- For ducted extraction extraction kit (accessory HZ381400) needed
- For recirculated extraction cleanAir recirculating kit (accessory HZ381501) needed
- Automatic switch-on of ventilation system when a cooking zone is used
- Sensor-based, fully automatic adjustment of power levels ( manual control possible)
- Automatic 30 minutes run-on function
- High-performance blower, Efficient BLDC-technology
- Cast-iron air inlet grid, heat resistant, dishwasher safe
- Removable and detachable grease filter and liquid collector unit, dishwasher safe
- - integrated stainless steel grease filters, dishwasher safe - condensate and liquid collector unit; ca. 200ml capacity; dishwasher safe

- Liquid spillover safety tank, ca. 2.000ml capacity, Twist-off lock, dishwasher safe
- Saturation indicator for grease filter
- Saturation indicator for cleanAir odor filter

### Technical Information

- Floor cupboard width: min. 80 cm.
- Worktop depth: min. 60 cm (with shortened drawers), max. drawer's depth can be used starting with a worktop depth of 70 cm.
- Immersion depth: 19.8 cm
- Modules for ducted extraction or re-circulated extraction must be ordered separately as special accessory.
- The appliance must be freely accessible from below.
- Appliance dimensions (H x W x D): 20 cm x 81 cm x 52 cm
- Length wire connection: 110 cm
- Total Connected load: 7.4 KW

**iQ700, Induction hob with integrated ventilation system, 80 cm, surface mount with frame EX875LX34E**

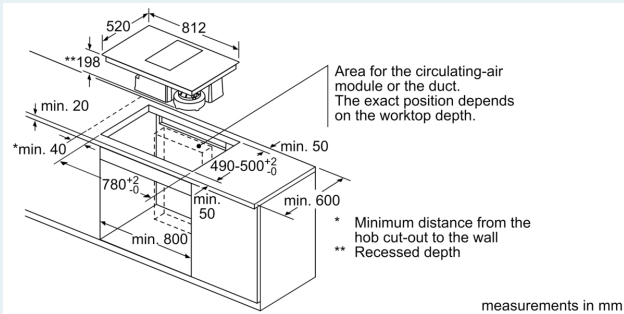

measurements in mm

