

**Serie | 8, heat pump tumble dryer, 9 kg
WTYH6791GB**



A++

The heat pump dryer with SelfCleaning Condenser™ and Home Connect: Convenient remote operation via smartphone or tablet PC.

- Automatic condenser cleaning guarantees a high drying performance and offers low energy consumption with an A++ rating.
- **AutoDry:** gently dries laundry to exactly the degree of dryness you want.
- **AntiVibration Design:** extremely stable and especially quiet thanks to special vibration protection.
- Easy to operate thanks to the intuitive user interface, and many program options.
- **Fast drying:** dries a full load considerably fast.



Technical Data

Built-in / Free-standing :	Free-standing
Removable top :	No
Door hinge :	Right reversible
Length electrical supply cord (cm) :	145.0
Height of removable worktop (mm) :	842
Dimensions of the product (mm) :	842 x 598 x 599
Net weight (kg) :	53.970
Fluorinated greenhouse gases :	No
Type of refrigerant :	R290
Hermetically sealed equipment :	Yes
Quantity of fluorinated gases (kg) :	0.149
The quantity expressed in CO2 equivalent (t) :	0.000
Power consumption standby/network: Please check the user manual for how to switch off the WiFi module. :	2.5
Time auto-standby/network :	15.0
EAN code :	4242005100897
Connection Rating (W) :	1000
Current (A) :	10
Voltage (V) :	220-240
Frequency (Hz) :	50
Approval certificates :	CE, VDE
Capacity cotton (kg) - NEW (2010/30/EC) :	9.0
Energy efficiency rating :	A++
Energy consumption electric dryer, full load - NEW (2010/30/EC) (kWh) :	2.06
Standard cotton programme time at full load (min) :	166
Energy consumption electric dryer, partial load - NEW (2010/30/EC) (kWh) :	1.24
Standard cotton programme time at partial load (min) :	108
Weighted annual energy consumption, electric dryer - NEW (2010/30/EC) (kWh) :	259.0
Weighted programme time (min) :	133
Average condensation efficiency full load (%) :	91
Average condensation efficiency partial load (%) :	91
Weighted condensation efficiency (%) :	91

Optional accessories

- WTZ11400 : Stacking kit with pull-out shelf
WTZ20410 : Stacking kit



Serie | 8, heat pump tumble dryer, 9 kg WTYH6791GB

The heat pump dryer with SelfCleaning Condenser™ and Home Connect: Convenient remote operation via smartphone or tablet PC.

Performance

- Energy Efficiency Class: A++ at a range of energy efficiency classes from A+++ to D
- Capacity: 9 kg
- Energy consumption 259.0 kWh per year, based on 160 drying cycles of the standard cotton programme at full and partial load, and the consumption of the low-power modes. Actual energy consumption per cycle will depend on how the appliance is used
- Energy consumption of the standard cotton programme at full load 2.06 kWh and energy consumption of the standard cotton programme at half load 1.24 kWh
- The programme Cotton cupboard dry used at full and partial load is the standard drying programme to which the information in the label and the fiche relates, this programme is suitable for drying normal wet cotton laundry and is the most efficient programme in terms of energy consumption for cotton.
- Programme time of the standard cotton programme at full load 166 min and programme time of the standard cotton programme at partial load 108 min.
- Weighted programme time of the standard cotton programme at full and partial load: 133 min.
- Condensation efficiency class A on a scale from G (least efficient) to A (most efficient).
- Average condensation efficiency of the standard cotton programme at full load 91 % and average condensation efficiency of the standard cotton programme at partial load 91 %.
- Weighted condensation efficiency for the standard cotton programme at full and partial load: 91 %.
- Power consumption in off-mode 0.1 W and in left-on mode 0.1 W
- Duration of left-on mode: 30 min
- Noise level: 64 dB (A) re 1 pW

Programmes/functions

- Fully electronic control dial for sensor drying programmes and timed programmes
- Special programmes: Mixed Load, wool drying in basket, Towels, Duvet, Timed programme warm, Timed programme cold, Cottons, Easy-Care, Allergy +, Sportswear, Down, Super Quick 40, shirts/blouses, Delicates
- Touch control buttons: Reduced ironing, start/pause, Options, Drying aim, Memory 1, Memory 2, Power button, Prog 3 sec., 24 h end Time Delay, Reduced ironing, Drying aim, Memory

1, Memory 2, Options, Power button, Prog 3 sec., end Time Delay, start/pause

Key features

- Home Connect: Remote Monitoring and Control
- ActiveAir Technology
- Heat Pump with self cleaning condenser
- Heat pump technology with climate friendly cooling agent
- Self Cleaning
- Sensitive drying: large stainless steel drum with textile care and revolution drying system
- AntiVibration design: for greater stability and quietness

Additional features

- TFT clear text display for easy use
- Jog dial
- Anti crease cycle 120 minutes at the end of the programme
- Wool drying basket
- Drum interior light
- Full container tank indicator
- Child Lock
- Buzzer to indicate the end of cycle
- Door hinge: right-hand, reversible
- Container for condensed water

Technical Information

- Dimensions (H x W x D): 84.2 x 59.8 x Appliance depth: 63.4 cm
- slide-under installation
- Glass door, chrome, white

**Serie | 8, heat pump tumble dryer, 9 kg
WTYH6791GB**

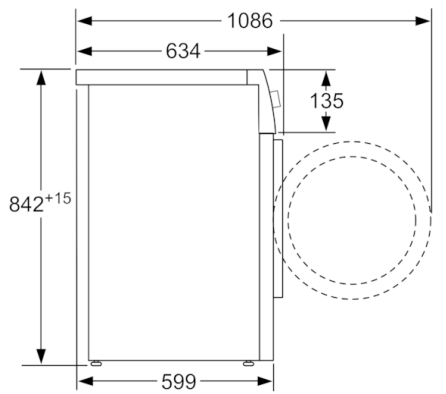

measurements in mm

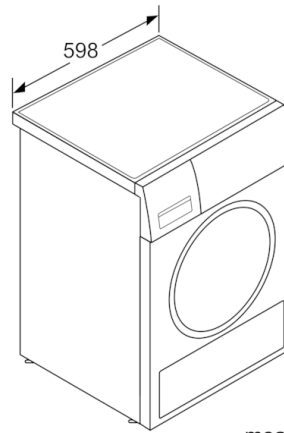

measurements in mm