

Serie | 8

WTYH6790GB
SelfCleaning Condenser
Condenser tumble dryer with
heat pump



A++

The heat pump dryer with SelfCleaning Condenser™ and Home Connect: Convenient remote operation via smartphone or tablet PC.

- **Home Connect:** home appliances with smart connectivity for an easier everyday life.
- **Energy efficiency class A++:** for extremely efficient drying.
- **SelfCleaning Condenser™:** no more manual cleaning, plus energy savings in class A++ for the life of the dryer.
- **Fast drying:** dries a full load up to 35 min faster than before.
- Easy to operate thanks to the intuitive user interface, and many program options.

Technical Data

Built-in / Free-standing :	Free-standing
Removable top :	No
Door hinge :	Right reversible
Length electrical supply cord (cm) :	145.0
Height of removable worktop (mm) :	842
Dimensions of the product (mm) :	842 x 598 x 599
Net weight (kg) :	56.254
Fluorinated greenhouse gases :	Yes
Type of refrigerant :	R407C
Hermetically sealed equipment :	Yes
Quantity of fluorinated gases (kg) :	0.290
The quantity expressed in CO2 equivalent (t) :	0.514
Power consumption standby/network: Please check the user manual for how to switch off the WiFi module. :	2.5
Time auto-standby/network :	15.0
EAN code :	4242002948287
Connection Rating (W) :	1000
Current (A) :	10
Voltage (V) :	220-240
Frequency (Hz) :	50
Approval certificates :	CE, VDE
Capacity cotton (kg) - NEW (2010/30/EC) :	9.0
Standard cotton programme :	Cotton cupboard dry
Energy efficiency class (2010/30/EC) :	A++
Energy consumption electric dryer, full load - NEW (2010/30/EC) (kWh) :	2.13
Standard cotton programme time at full load (min) :	157
Energy consumption electric dryer, partial load - NEW (2010/30/EC) (kWh) :	1.21
Standard cotton programme time at partial load (min) :	97
Weighted annual energy consumption, electric dryer - NEW (2010/30/EC) (kWh) :	258.0
Weighted programme time (min) :	123
Average condensation efficiency full load (%) :	87
Average condensation efficiency partial load (%) :	94
Weighted condensation efficiency (%) :	91



Serie | 8 Tumble Dryer

WTYH6790GB

SelfCleaning Condenser Condenser tumble dryer with heat pump

The heat pump dryer with SelfCleaning Condenser™ and Home Connect: Convenient remote operation via smartphone or tablet PC.

Performance

- Energy Efficiency Class: A++ at a range of energy efficiency classes from A+++ to D
- Capacity: 9 kg
- Energy consumption 258.0 kWh per year, based on 160 drying cycles of the standard cotton programme at full and partial load, and the consumption of the low-power modes. Actual energy consumption per cycle will depend on how the appliance is used
- Energy consumption of the standard cotton programme at full load 2.13 kWh and energy consumption of the standard cotton programme at half load 1.21 kWh
- The programme Cottons cupboard dry used at full and partial load is the standard drying programme to which the information in the label and the fiche relates, this programme is suitable for drying normal wet cotton laundry and is the most efficient programme in terms of energy consumption for cotton.
- Programme time of the standard cotton programme at full load 157 min and programme time of the standard cotton programme at partial load 97 min.
- Weighted programme time of the standard cotton programme at full and partial load: 123 min.
- Condensation efficiency class A on a scale from G (least efficient) to A (most efficient).
- Average condensation efficiency of the standard cotton programme at full load 87 % and average condensation efficiency of the standard cotton programme at partial load 94 %.
- Weighted condensation efficiency for the standard cotton programme at full and partial load: 91 %.
- Power consumption in off-mode 0.1 W and in left-on mode 0.1 W
- Duration of left-on mode: 30 min
- Noise level: 64 dB (A) re 1 pW

Programmes/functions

- Fully electronic control dial for sensor drying programmes and timed programmes
- Special programmes: Mixed Load, wool drying in basket, Towels, Blankets, Timed programme warm, Timed programme

cold, Cottons, Easy-Care, Allergy +, Sportswear, Down, Super Quick 40, shirts/blouses, Delicates

- Touch control buttons: Reduced ironing, start/pause, Options, Drying aim, Memory 1, Memory 2, Power button, Prog 3 sec., 24 h end Time Delay

Key features

- Home Connect: Remote Monitoring and Control
- Heat Pump with self cleaning condenser
- Sensitive drying: large stainless steel drum with textile care and revolution drying system
- AntiVibration design: for greater stability and quietness

Additional features

- TFT clear text display for easy use
- Anti crease cycle 120 minutes at the end of the programme
- Jog dial
- Drum interior light
- Child Lock
- Buzzer to indicate the end of cycle
- Door hinge: reversible, right-hand
- Container for condensed water

Technical Information

- Dimensions (H x W x D): 84.2 x 59.8 x 59.9 cm
- slide-under installation
- Glass door chrome, white

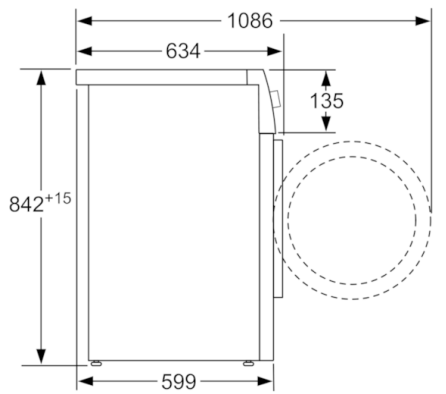
Serie | 8 Tumble Dryer**WTYH6790GB****SelfCleaning Condenser****Condenser tumble dryer with heat pump**

measurements in mm

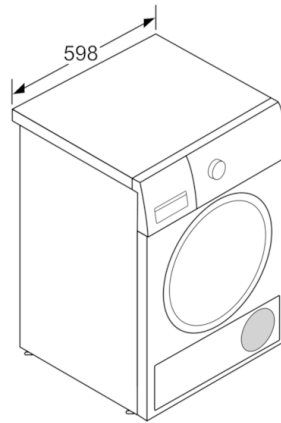

measurements in mm