

**Series 8, heat pump tumble dryer, 9 kg
WTX88EH9GB**



The AutoClean dryer with Smart Dry and Iron Assist is the most convenient and smartest dryer ever.

- **Iron Assist:** Extra steam treatment to smooth dried laundry, or even skip ironing altogether.
- **AutoDry:** gently dries laundry to exactly the degree of dryness you want.
- **Easy to operate thanks to the intuitive user interface, and many program options.**
- **Sensitive Drying system:** soft, even drying thanks to the unique drum structure.
- **SensitiveDrying System:** the unique drum structure protects and delivers a drying performance without creases.

Technical Data

Built-in / Free-standing:	Free-standing
Removable top:	No
Door hinge:	Right reversible
Length electrical supply cord:	179.5 cm
Dimensions:	842 x 598 x 613 mm
Net weight:	57.3 kg
Fluorinated greenhouse gases:	No
Type of refrigerant:	R290
Hermetically sealed equipment:	Yes
EAN code:	4242005179039
Connection rating:	600 W
Fuse protection:	10 A
Voltage:	220-240 V
Frequency:	50 Hz
Loading capacity:	9.0 kg
Energy efficiency rating:	A+++
Energy consumption electric dryer, full load - NEW (2010/30/EC):	1.61 kWh
Standard cotton programme time at full load:	215 min
Energy consumption electric dryer, partial load - NEW (2010/30/EC):	0.90 kWh
Standard cotton programme time at partial load:	132 min
Weighted annual energy consumption, electric dryer - NEW (2010/30/EC):	193.0 kWh/annum
Weighted programme time:	168 min
Average condensation efficiency full load (%):	88 %
Average condensation efficiency partial load (%):	88 %
Weighted condensation efficiency (%):	88 %

Optional accessories

WMZ20600	Wool in basket - accessory
WTZ27400	Stacking kit with pull-out shelf
WTZ27410	Stacking kit
WTZPW20D	Platform with pull-out, dryer, cubic



Series 8, heat pump tumble dryer, 9 kg WTX88EH9GB

The AutoClean dryer with Smart Dry and Iron Assist is the most convenient and smartest dryer ever.

Performance

- Energy Efficiency Class: A+++ at a range of energy efficiency classes from A+++ to D
- Capacity: 9 kg
- Energy consumption 193.0 kWh per year, based on 160 drying cycles of the standard cotton programme at full and partial load, and the consumption of the low-power modes. Actual energy consumption per cycle will depend on how the appliance is used
- Energy consumption of the standard cotton programme at full load 1.61 kWh and energy consumption of the standard cotton programme at half load 0.9 kWh
- The programme Cotton cupboard dry used at full and partial load is the standard drying programme to which the information in the label and the fiche relates, this programme is suitable for drying normal wet cotton laundry and is the most efficient programme in terms of energy consumption for cotton.
- Programme time of the standard cotton programme at full load 215 min and programme time of the standard cotton programme at partial load 132 min.
- Weighted programme time of the standard cotton programme at full and partial load: 168 min.
- Condensation efficiency class B on a scale from G (least efficient) to A (most efficient).
- Average condensation efficiency of the standard cotton programme at full load 88 % and average condensation efficiency of the standard cotton programme at partial load 88 %.
- Weighted condensation efficiency for the standard cotton programme at full and partial load: 88 %.
- Power consumption in off-mode 0.1 W and in left-on mode 0.1 W
- Duration of left-on mode: 30 min
- Noise level: 62 dB (A) re 1 pW

Programmes/functions

- Fully electronic control dial for sensor drying programmes and timed programmes
- Standard programmes: cotton, easy care
- Special programmes: Allergy +, Cottons, shirts/blouses, Connected Dry, Down, Delicates, Towels, ColdRefresh_1piece, ColdRefresh_5pieces, ColdRefreshBusiness, Mixed Load, Super Quick 40, Sportswear, Duvet, Easy-Care, wool drying in basket, Woollens, Further programs, Timed programme cold, Timed programme warm
- Touch control buttons: Prog 3 sec., end Time Delay, Reduced ironing, Memory 1, Memory 2, Options, Power button, Remote Start, Start / Reload / Pause, Drying aim, 24 h end Time Delay

Key features

- Home Connect: Remote Monitoring and Control, Energy Management
- Iron Assist
- AutoClean
- Heat pump technology with climate friendly cooling agent

- Sensitive drying: large stainless steel drum with textile care and revolution drying system
- AntiVibration design: for greater stability and quietness

Additional features

- TFT clear text display for easy use
- Jog dial
- Anti crease cycle 120 minutes at the end of the programme
- Drum interior light
- Wool drying basket
- Child Lock
- Buzzer to indicate the end of cycle
- Door hinge: right-hand, reversible
- Container for condensed water

Technical Information

- slide-under installation
- Glass door, chrome, white
- Dimensions (H x W x D): 84.2 x 59.8 x Appliance depth: 63.4 cm
- Appliance depth: 59.9 cm
- Appliance depth incl. door: 63.4 cm
- Appliance depth with open door: 108.6 cm

**Series 8, heat pump tumble dryer, 9
kg
WTX88EH9GB**

Measurements in mm

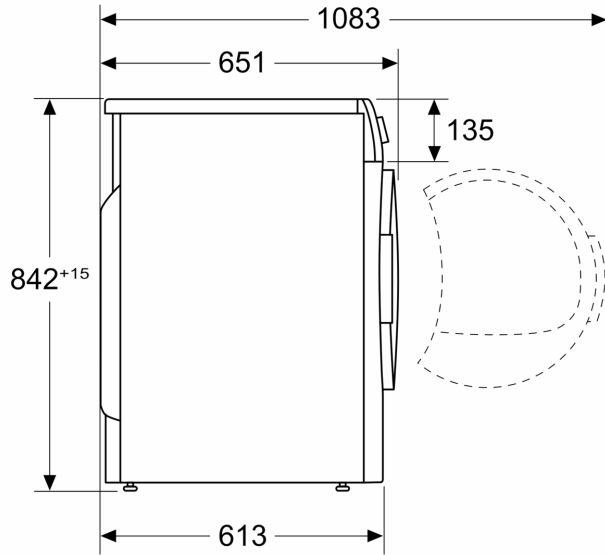

Measurements in mm

