

**Series 8, Heat pump tumble dryer, 9 kg**  
**WQB246C9GB**

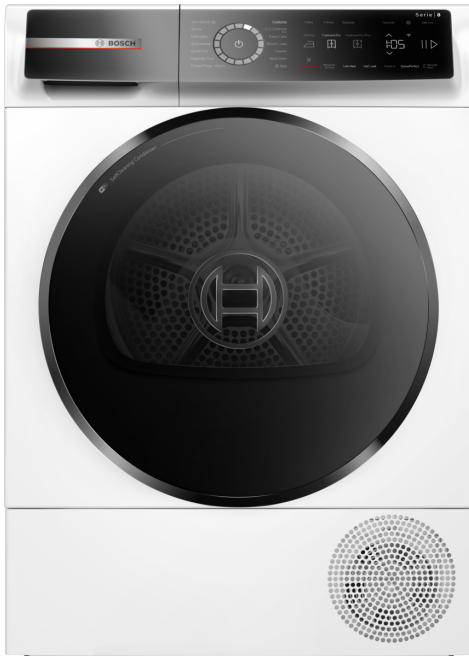

**A+++**



**An exceptional heatpump dryer with Smart Dry powered by Home Connect. Maximise your energy savings with A+++ -10%\* and the Self Cleaning condenser. Protect your Garments with Auto Dry and reduce your ironing Pile with Iron Assist.**

- **Auto Dry:** automatically dries to the exact level of dryness you want.
- **SelfCleaning Condenser:** keep the condenser free of fluff to maintain top A+++ energy efficiency.
- **SmartDry:** your connected dryer and washer recommend the right drying programme.
- **Home Connect:** home appliances with smart connectivity to make everyday life easier.
- **Iron Assist:** steam treatment that reduces wrinkles, and your ironing pile.

**Technical Data**

Built-in / Free-standing: .....	Free-standing
Removable top: .....	No
Door hinge: .....	Right reversible
Length electrical supply cord: .....	180.0 cm
Dimensions: .....	842 x 598 x 613 mm
Net weight: .....	55.2 kg
Fluorinated greenhouse gases: .....	No
Type of refrigerant: .....	R290
Hermetically sealed equipment: .....	Yes
EAN code: .....	4242005364428
Connection rating: .....	600 W
Fuse protection: .....	10 A
Voltage: .....	220-240 V
Frequency: .....	50 Hz
Loading capacity: .....	9.0 kg
Energy efficiency rating: .....	A+++
Energy consumption electric dryer, full load - NEW (2010/30/EC):	1.44 kWh
Standard cotton programme time at full load: .....	260 min
Energy consumption electric dryer, partial load - NEW (2010/30/EC):	0.80 kWh
Standard cotton programme time at partial load: .....	156 min
Weighted annual energy consumption, electric dryer - NEW (2010/30/EC):	174.0 kWh/annum
Weighted programme time: .....	201 min
Average condensation efficiency full load (%): .....	91 %
Average condensation efficiency partial load (%): .....	91 %
Weighted condensation efficiency (%): .....	91 %

**Optional accessories**

WMZ20600	Wool in basket - accessory
WTZ27500	Stacking kit with pull-out shelf
WTZ27510	Stacking kit
WTZPW20D	Platform with pull-out, dryer, cubic



## Series 8, Heat pump tumble dryer, 9 kg WQB246C9GB

**An exceptional heatpump dryer with Smart Dry powered by Home Connect. Maximise your energy savings with A+++ -10%\* and the Self Cleaning condenser. Protect your Garments with Auto Dry and reduce your ironing Pile with Iron Assist.**

- Appliance depth incl. door: 65.1 cm
- Appliance depth with open door: 110.5 cm
- Heat pump technology with climate friendly cooling agent

- <sup>1</sup> At a range of energy efficiency classes from A+++ to D
- <sup>3</sup> Programme time of the standard cotton programme at full load
- <sup>4</sup> On a condensation efficiency class scale from A to G
- <sup>5</sup> Weighted condensation efficiency for the standard cotton programme at full and partial load

### Performance

- Energy Efficiency Class<sup>1</sup>: A+++
- Energy<sup>2</sup>: 174 kWh
- Capacity: 1 - 9 kg
- Programme time<sup>3</sup>: 260 min
- Noise level: 58 dB (A) re 1 pW
- Condensation efficiency class<sup>4</sup>: A
- Condensation efficiency<sup>5</sup>: 91 %

### Programmes/functions

- Standard programmes: cotton, easy care
- Bed Linen Program: reduces tangling of big items thanks to reversible drum
- Special programmes: Cottons, shirts/blouses, Cotton Eco, Delicates, Towels, Mixed Load, Sportswear, Easy-Care, Timed programme warm

### Key features

- Half Load option: optimises drying for smaller loads
- Anti crease cycle 120 min at the end of the programme
- Touch control buttons: Iron dry, Cupboard dry, Cupboard dry+, end Time Delay, Reduced ironing, My favorite, Power button, Remote Start, Low heat, Start / Reload / Pause, speedPerfect, 24 h end Time Delay

### Additional features

- SC1R
- BLDC/twin rotary
- Load recommendation
- Fully electronic control dial for sensor drying programmes and timed programmes
- Sensitive drying: large stainless steel drum with textile care and revolution drying system
- AntiVibration design: for greater stability and quietness
- No
- Drum interior light
- Container for condensed water
- Child Lock
- Buzzer to indicate the end of cycle
- Usage meter: counts completed programmes
- Door hinge: right-hand, reversible
- Metal door catch

### Technical Information

- slide-under installation
- Dimensions (H x W): 84.2 cm x 59.8 cm
- Appliance depth: 61.3 cm

**Series 8, Heat pump tumble dryer, 9  
kg  
WQB246C9GB**

Measurements in mm

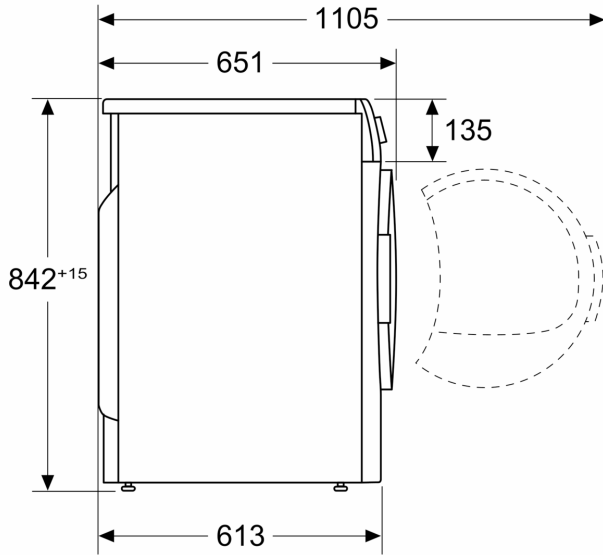

Measurements in mm

