

**Series 6, Washing machine, front loader, 9 kg, , Silver inox WGG2440XGB**



**Perfect results with minimum energy and water consumption, thanks to energy Class A and ActiveWater Plus.**

- **Speed Perfect:** get the perfect clean in up to 65% less time.
- **AntiStain:** reliably removes four common stains.
- **ActiveWater Plus:** For highly efficient use of water even with smaller loads thanks to automatic load detection.
- **EcoSilence Drive™:** quiet and energy-efficient drive, with a 10-year warranty.
- **Best energy class A:** save energy with the most efficient class A.

**Technical Data**

Energy Efficiency Class: ..... A  
 Weighted energy consumption in kWh per 100 washing cycles of eco 40-60 programme: ..... 46 kWh  
 Maximum capacity in kg: ..... 9.0 kg  
 The water consumption of the eco programme in liters per cycle: 48 l  
 Duration of eco 40-60 programme in hours and mins at rated capacity: ..... 3:48 h  
 Spin-drying efficiency class of eco 40-60 programme: ..... B  
 Airborne acoustical noise emission class: ..... A  
 Airborne acoustical noise emissions : ..... 71 dB(A) re 1 pW  
 Built-in / Free-standing: ..... Free-standing  
 Dimensions of the product: ..... 848 x 598 x 590 mm  
 Net weight: ..... 73.5 kg  
 Connection rating: ..... 2300 W  
 Fuse protection: ..... 10 A  
 Voltage: ..... 220-240 V  
 Frequency: ..... 50-60 Hz  
 Length electrical supply cord: ..... 210.0 cm  
 Door hinge: ..... Left  
 Wheels: ..... No  
 EAN code: ..... 4242005307708  
 Installation typology: ..... Free-standing

**Optional accessories**

- WMZ2200 Floor securing component
- WMZ2381 Extension for cold water inlet /Aquastop
- WMZPW20W Platform with pull-out, washer, cubic



## Series 6, Washing machine, front loader, 9 kg, , Silver inox WGG2440XGB

### Perfect results with minimum energy and water consumption, thanks to energy Class A and ActiveWater Plus.

- silver inox Edition

#### Performance

- Energy Efficiency Class<sup>1</sup>: A
- Energy<sup>2</sup> / Water<sup>3</sup>: 46 kWh / 48 litres
- Load capacity: 1 - 9 kg
- Programme duration<sup>4</sup>: 3:48 h:min
- Spin drying efficiency class: B
- Spin speed<sup>\*\*</sup>: 400 - 1400 rpm
- Noise level: 71 dB (A) re 1 pW
- Noise efficiency class: A

#### Programmes/functions

- Touch control buttons: Reduced Ironing option, Ready in, stain selection, start/pause with reload function, Temperature selection, SpeedPerfect, Prewash, Spin speed reduction, Aqua Plus/Rinse Hold
- Standard programmes: cottons, easy care, delicates, wool hand wash
- Special programmes: Drum clean with reminder, Jeans, Drain / Spin, Mixed Load, SportsWear, Single Rinse, Duvet, Super Quick 15/30, Hygiene

#### Key features

- SpeedPerfect: perfectly clean in up to 65% less time. \*\*\*
- AntiStain - 4 stain removal options at the touch of a button
- Reload function: Be flexible in adding laundry items even after start of the wash cycle.
- AntiVibration Design - for more stability and quietness
- Sensor electronics with safeguard monitoring system that adjusts load and distribution and programme settings to protect clothes
- EcoSilence drive with 10 year warranty

#### Additional features

- Large LED-Display for programme status indication, max. spin speed, remaining time and 24 h end time delay and load recommendation
- Hygiene Plus: clean laundry and killing germs effectively
- Drum volume: 65 litres
- VarioDrum: gentle and efficient washing
- Drum clean with reminder function
- ActiveWater Plus: for highly efficient use of water even with small loads thanks to automatic load detection.
- AntiStain
- Detergent dispensing: easy clean
- Divider for Liquid Detergent
- Aqua Protection
- soft dial
- Foam detection system
- Child lock
- Acoustic signals: Buzzer

#### Technical Information

- Slide-under installation
- Large Silver-inox, black-grey door with 165° opening and 32cm porthole opening
- Dimensions (H x W): 84.8 cm x 59.8 cm
- Appliance depth: 59.0 cm
- Appliance depth incl. door: 63.6 cm
- Appliance depth with open door: 107.3 cm

<sup>1</sup> Scale of Energy Efficiency Classes from A to G

<sup>2</sup> Energy consumption in kWh per 100 cycles (in programme Eco 40-60)

<sup>3</sup> Weighted water consumption in litres per cycle (in programme Eco 40-60)

<sup>4</sup> Duration of Eco 40-60 programme

\*\* Values are rounded.

\*\*\* Comparison between the program duration of Easy-care 40°C and the program duration of Easy-care 40°C + activated Speed option

**Series 6, Washing machine, front loader, 9 kg, , Silver inox  
WGG2440XGB**

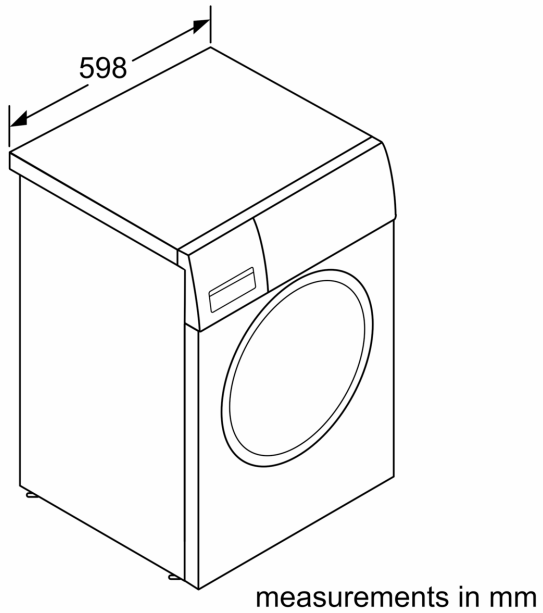

Measurements in mm

