

**Series 8, Washing machine, front loader, 10 kg, 1400 rpm
WGB256A1GB**



An exceptional washing machine with i-Dos and detergent scan powered by Home Connect which saves water and detergent. Maximise your energy savings with A-20%* and reduce your ironing pile with Iron Assist.

- **Best energy class A:** save energy with the most efficient class A.
- **Speed Perfect:** get the perfect clean in up to 65% less time.
- **i-DOS with Detergent Scan:** save on detergent by no longer dosing manually.
- **10kg VarioDrum:** enough space for big loads or large items
- **Home Connect:** home appliances with smart connectivity for an easier everyday life.

Technical Data

Energy Efficiency Class:	A
Weighted energy consumption in kWh per 100 washing cycles of eco 40-60 programme:	41 kWh
Maximum capacity in kg:	10.0 kg
The water consumption of the eco programme in liters per cycle:	49 l
Duration of eco 40-60 programme in hours and mins at rated capacity:	3:50 h
Spin-drying efficiency class of eco 40-60 programme:	B
Airborne acoustical noise emission class:	A
Airborne acoustical noise emissions :	70 dB(A) re 1 pW
Built-in / Free-standing:	Free-standing
Height of removable worktop:	-5 mm
Dimensions of the product:	845 x 598 x 590 mm
Net weight:	82.8 kg
Connection rating:	2300 W
Fuse protection:	10 A
Voltage:	220-240 V
Frequency:	50-60 Hz
Length electrical supply cord:	210.0 cm
Door hinge:	Left
Wheels:	No
EAN code:	4242005396214
Installation typology:	Free-standing

Optional accessories

- WMZPW20W Platform with pull-out, washer, cubic
- WMZ2200 Floor securing component
- WMZ2381 Extension for cold water inlet /Aquastop



Series 8, Washing machine, front loader, 10 kg, 1400 rpm WGB256A1GB

An exceptional washing machine with i-Dos and detergent scan powered by Home Connect which saves water and detergent. Maximise your energy savings with A-20%* and reduce your ironing pile with Iron Assist.

Performance

- Energy Efficiency Class¹: A
- Energy² / Water³: 41 kWh / 49 litres
- Load capacity: 1 - 10 kg
- Programme duration⁴: 3:50 h:min
- Spin drying efficiency class: B
- Spin speed^{**}: 400 - 1400 rpm
- Noise level: 70 dB (A) re 1 pW
- Noise efficiency class: A

Programmes/functions

- Standard programmes: cottons, easy care, delicates, wool hand wash
- W_F55C-PG1.5CU-i
- Iron Assist: Steam programme that reduces wrinkles on dry clothes
- Special programmes: Automatic, Drain / Spin, Mixed Load, SportsWear, Single Rinse, Super Quick 15/30, Hygiene

Key features

- i-DOS: automatic dosing of liquid detergent and softener
- Touch control buttons: On/off, Ready in, stain selection, i-DOS 1, i-DOS 2, child lock, Memory, Power rinse, Remote Start, start/pause with reload function, Temperature selection, SpeedPerfect, Prewash, Spin speed reduction/Rinse Hold

Additional features

- Reload function: Be flexible in adding laundry items even after start of the wash cycle.
- 4D Wash System: highly efficient water and detergent fabric penetration for spotless results.
- Hygiene Plus: clean laundry and killing germs effectively
- Drum volume: 70 litres
- Drum interior light
- VarioDrum: gentle and efficient washing
- Large black-chrome, black door with 182° opening and 32cm porthole opening
- Reload function / pause function
- EcoSilence drive with 10 year warranty
- AntiVibration Design - for more stability and quietness
- ActiveWater Plus: for highly efficient use of water even with small loads thanks to automatic load detection.
- Sound insulation by additional noise reduction material
- Turbidity sensor
- AquaStop: Bosch home appliance with lifetime warranty against water damage*
- Foam detection system

- Overdosage indication
- Sensor electronics with safeguard monitoring system that adjusts load and distribution and programme settings to protect clothes
- Child lock
- Acoustic signals: Buzzer
- Detergent dispensing: i-DOS 2.0
- Usage meter: counts completed programmes

Technical Information

- Slide-under installation
- Dimensions (H x W): 84.5 cm x 59.8 cm
- Appliance depth: 59.0 cm
- Appliance depth incl. door: 64.8 cm
- Appliance depth with open door: 109.0 cm

¹ Scale of Energy Efficiency Classes from A to G

² Energy consumption in kWh per 100 cycles (in programme Eco 40-60)

³ Weighted water consumption in litres per cycle (in programme Eco 40-60)

⁴ Duration of Eco 40-60 programme

** Values are rounded.

* Please find warranty terms under: BSHM_BMRK_BL

**Series 8, Washing machine, front loader, 10 kg, 1400 rpm
WGB256A1GB**

Measurements in mm

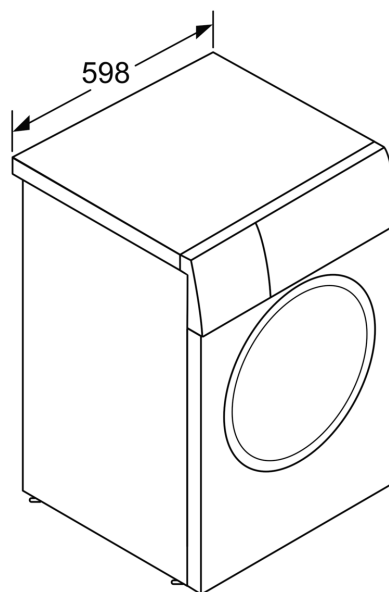
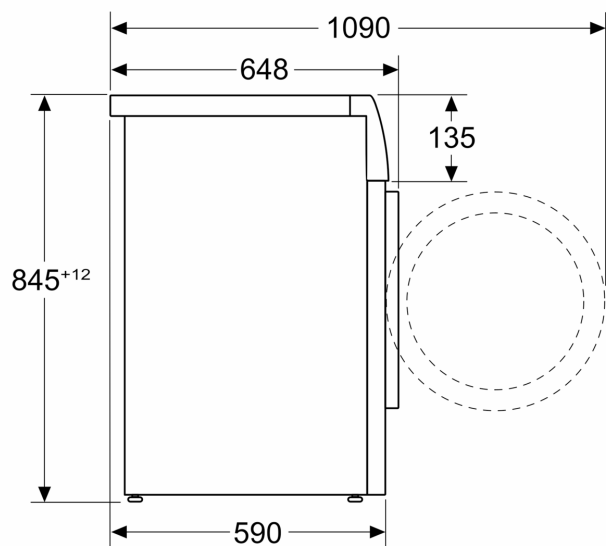

measurements in mm