

iQ500, telescopic cooker hood, 90 cm, Stainless steel LI97SA560B

B



For clean lines the powerful telescopic cooker hood disappears into an upper cabinet, perfect for modern kitchens.

- ✓ iQdrive motor - The quiet, high-performance motor ensures efficient removal of odours and steam.
- ✓ LED lights: for optimal visibility and ambience while cooking.
- ✓ Extremely quiet – The quiet hood that keeps the calm your kitchen.

Features

Technical Data

Typology : Pull-out
 Approval certificates : CE, VDE
 Length electrical supply cord : 175 cm
 Required niche size for installation (HxWxD) : 385mm x 524.0mm x 290mm mm
 Minimum distance above an electric hob : 430 mm
 Minimum distance above a gas hob : 650 mm
 Net weight : 14.055 kg
 Type of control : Electronic
 Number of speed settings : 3-stage + 2 intensive
 Maximum output air extraction : 395 m³/h
 Boost position output recirculating : 628 m³/h
 Maximum output recirculating air : 358 m³/h
 Boost position air extraction : 708 m³/h
 Number of lights : 2
 Noise level : 56 dB(A) re 1 pW
 Diameter of air outlet : 150 / 120 mm
 Grease filter material : Washable stainless steel
 EAN code : 4242003745755
 Connection Rating : 146 W
 Fuse protection : 10 A
 Voltage : 220-240 V
 Frequency : 60; 50 Hz
 Plug type : GB plug
 Installation typology : Built-in

Optional accessories

LZ49560	Handle strip black
LZ49200	Installation kit for 90cm wide wall unit
LZ45650	Standard recirculation kit
LZ45610	Standard odor filter (replacement)
LZ10ITP00	Long Life odor filter (replacement)



4 242003 745755

iQ500, telescopic cooker hood, 90 cm, Stainless steel LI97SA560B

Features

Key Information

- Soft touch button control with 7-segment display
- 3 power levels and 2 intensive settings
- Automatic intensive revert (6mins)
- Silence kit
- 2 x LED lights
- SoftLight with dimmer function
- Neutral white lights
- Efficient BLDC motor
- Automatic after running (10 minutes)
- 3 x metal grease filter cassettes - dishwasher safe
- Grease and charcoal filter saturation indicators
- Steel filter cover

Design

- 90 cm Extractor hood with telescopic canopy
- Installation system: Telescopic comfort installat.
- Stainless Steel
- Electronic control via Soft touch button control
- Blue indicator lights

Performance/technical information

- Suitable for ducted and re-circulating operation
- For recirculated extraction recirculating kit or CleanAir recirculating kit (accessory) needed
- Energy Efficiency Class: B (at a range of energy efficiency classes from A+++ to D)
- Extraction rate according to EN 61591 ø 15 cm:
 - max. Normal use 394 m³/h
 - Intensive 708 m³/h
- Noise level according to EN 60704-3 and EN 60704-2-13 exhaust air:
 - Max. normal use: 56 dB(A) re 1 pW
 - Intensive: 68 dB(A) re 1 pW
- With the Clean Air Plus recirculation kit (available as optional accessory) your appliances reaches:
 - Extraction rate in recirculation mode:
 - Max. normal use: 358 m³/h
 - Intensive: 628 m³/h
 - Noise level in recirculation mode:
 - Max. normal use: 60 dB(A) re 1 pW
 - Intensive: 71 dB(A) re 1 pW
- Additional noise reduction insulation
- Power rating: 146 W
- Light Intensity: 601 lux
- Colour Temperature: 3500 K
- Average Energy Consumption: 37.9 kWh/year*
- Blower Efficiency Class: B*
- Lighting Efficiency Class: A*
- Grease Filtering Efficiency Class: B*
- Diameter pipe Ø 150 mm (Ø 120 mm enclosed)
- Built-in dimensions (HxWxD): 385 x 524 x 290 mm
- Dimensions exhaust air (HxWxD): 426-426 x 898 x 290 mm

* In accordance with the EU-Regulation No 65/2014

**iQ500, telescopic cooker hood, 90 cm,
Stainless steel
LI97SA560B**

Dimensioned drawings

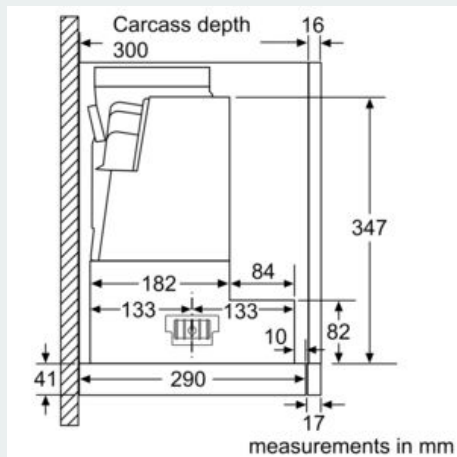
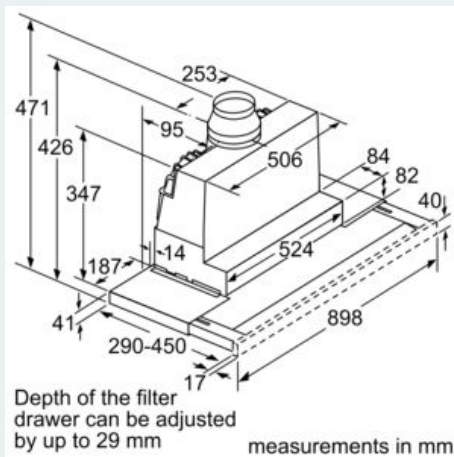
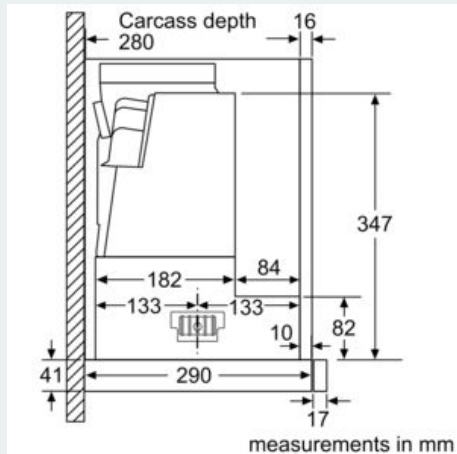
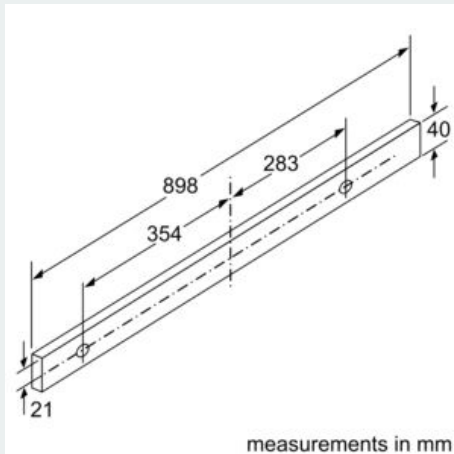
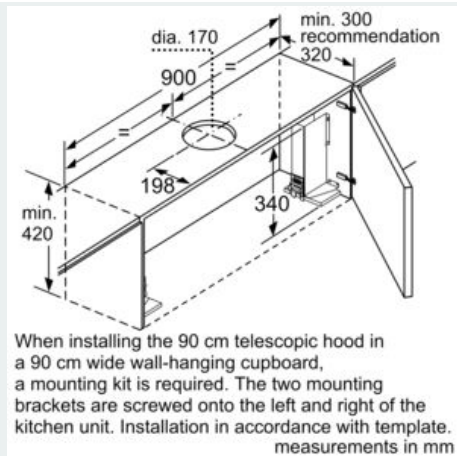
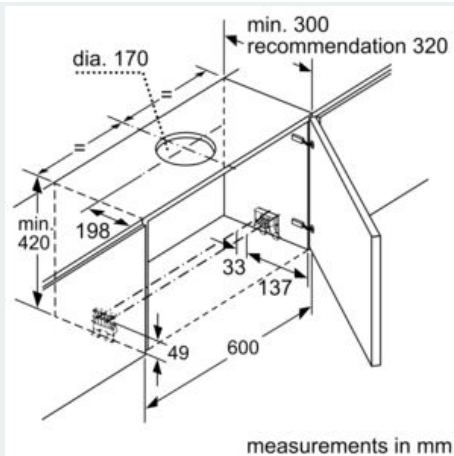

iQ500, telescopic cooker hood, 90 cm, Stainless steel LI97SA560B

Dimensioned drawings

