

iQ700, ceiling cooker hood, 90 cm, Stainless steel LF959RE55B

A



The sleek, space saving ceiling cooker hood for perfect integration into the ceiling.

- ✓ The quiet high-performance motor: ensures efficient odour and steam removal.
- ✓ LED lights: For optimal visibility and ambience when cooking.
- ✓ Calms the cooking process: extremely quiet
- ✓ For peak performance - Intensive setting with automatic revert

Features

Technical Data

Typology : Traditional
 Approval certificates : CE, NEMKO
 Length electrical supply cord (cm) : 140
 Required niche size for installation (HxWxD) : 327mm x 825.0mm x 425mm
 Minimum distance above an electric hob : 600
 Minimum distance above a gas hob : 900
 Net weight (kg) : 22.950
 Type of control : Electronic
 Maximum output air extraction (m³/h) : 492
 Boost position output recirculating (m³/h) : 510.0
 Boost position air extraction (m³/h) : 710
 Number of lights : 1
 Noise level (dB(A) re 1 pW) : 56
 Diameter of air outlet (mm) : 150
 Grease filter material : Washable aluminium
 EAN code : 4242003756584
 Connection Rating (W) : 188
 Current (A) : 16
 Voltage (V) : 220-240
 Frequency (Hz) : 50
 Plug type : GB plug
 Installation typology : Built-in

Optional accessories

LZ56700	cleanAir recirculating module
LZ56200	CleanAir active carbon filter spare part



4 242003 756584

iQ700, ceiling cooker hood, 90 cm, Stainless steel LF959RE55B

Features

Design

- 90 cm wide
- Stainless Steel
- Neutral white lights
- For ceiling mounted installation

Key Information

- Remote control
- Interval operation
- 1 x LED
- softLight with dimmer function
- 2 x metal grease filter cassettes
- Glass filter cover, Steel filter cover
- Rim ventilation

Performance/technical information

- Suitable for ducted and re-circulating operation
- For recirculated extraction CleanAir recirculating kit (accessory) needed
- Extraction rate according to EN 61591 \varnothing 15 cm: max. Normal use 460 m³/h Intensive 710 m³/h
- Noise level according to EN 60704-3 and EN 60704-2-13 exhaust air: Max. normal use: 56 dB(A) re 1 pW Intensive: 66 dB(A) re 1 pW
- iQDrive motor - efficient BLDC technology
- 3 x power levels plus intensive setting
- Power rating: 188 W
- Automatic intensive revert
- Noise max. Normal Level: 56 dB*
- Extractor hose 150 mm
- Dimensions (WxD): 900 x 500 mm
- built-in dimensions (HxWxD): 327 x 825 x 425 mm
- Dimensions exhaust air (HxWxD): 327-327 x 900 x 500 mm
- Diameter pipe \varnothing 150 mm (\varnothing 150 mm enclosed)
- Light Intensity: 1385 lux
- Colour Temperature: 3800 K
- Average Energy Consumption: 46.4 kWh/year*
- Energy Efficiency Class: A (at a range of energy efficiency classes from A+++ to D)
- Blower Efficiency Class: A*
- Lighting Efficiency Class: A*
- Grease Filtering Efficiency Class: D*

* In accordance with the EU-Regulation No 65/2014

**iQ700, ceiling cooker hood, 90 cm,
Stainless steel
LF959RE55B**

Dimensioned drawings

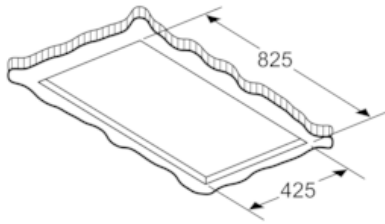

A suitable load-bearing substructure is required for securing the extractor hood. Never fit the appliance directly onto plasterboard or similar lightweight construction materials.

measurements in mm

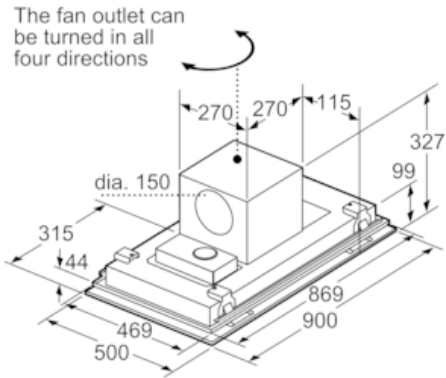

measurements in mm

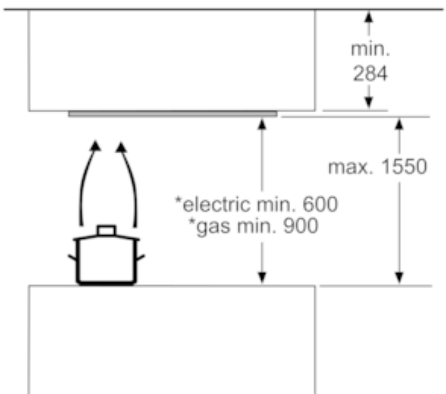

* from upper edge of pan support
measurements in mm