

IQ700, Wall-mounted cooker hood, 90 cm, Clear glass black printed LC97FVW69B



B



Flat design extractor hood with high extraction rate for a powerful performance.

- ✓ iQdrive motor - The quiet, high-performance motor ensures efficient removal of odours and steam.
- ✓ cookConnect system and climate control sensor: Perfect cooperation
- ✓ emotionLight Pro: Adapt your extractor hood to your style.
- ✓ voiceControl – Control hood functions and lighting using your voice.
- ✓ Home Connect – The app that makes your hood work smarter.

Features

Technical Data

Typology:	Wall-mounted
Length electrical supply cord:	130.0 cm
Height of the appliance:	430 mm
Minimum distance above an electric hob:	450 mm
Minimum distance above a gas hob:	650 mm
Weight:	25.5 kg
Type of control:	Electronic
Number of speed settings:	3-stage + 2 intensive
Maximum output air extraction:	394 m³/h
Boost position output recirculating:	404 m³/h
Maximum output recirculating air:	249 m³/h
Boost position air extraction:	717 m³/h
Maximum Air flow:	394 m³/h
Number of lights:	2
Noise level:	57 dB(A) re 1 pW
Diameter of air outlet:	150 / 120 mm
Grease filter material:	Other
EAN code:	4242003804285
Connection Rating:	150 W
Fuse protection:	10 A
Nominal power:	220-240 V
Frequency:	50; 60 Hz
Plug type:	GB plug
Installation type:	Wall-mounted
Delay Shut off modes:	10 min



Optional accessories

LZ10AXL50	Chimney extension 1500 mm
LZ11AFB16	Clean Air Plus odor filter (replacement)
LZ11AFI16	Clean Air Plus recirculation kit
LZ11AFV16	Clean Air Plus recirc. kit (chimless)
LZ11AXC56	Clean Air Plus recirc. kit external
LZ11AXE61	Chimney standard black
LZ31XXB16	Clean Air Plus odor filter (replacement)
LZ00XP00	Long Life odor filter (replacement)
LZ10AFR00	Long Life recirculation kit (chimless)
LZ10AF500	Long Life recirculation kit
LZ10AXK50	Chimney extension 1000 mm

IQ700, Wall-mounted cooker hood, 90 cm, Clear glass black printed LC97FVW69B

Features

Key performance features:

- Energy Efficiency Class: B (at a range of energy efficiency classes from A+++ to D)
- Extraction rate according to EN 61591 \varnothing 15 cm:
- max. Normal use 394 m³/h
- Intensive 717 m³/h
- Noise max. Normal Level: 57 dB*

Home Connect: Remote Monitoring and Control

- Home Connect: Remote Monitoring and Control for connected home appliances and operation via smartphone or tablet (only in countries where Home Connect service is available)
- The Home Connect functionality can be extended by integrating numerous applications from external cooperation partners (partnerships)
- Voice Control enabled via popular voice assistants (only in countries where this service is available)

Features

- climateControl sensor
- emotionLight pro: Ambient light
- Boost function
- cookConnect hob based hood control
- 3 power levels and 2 intensive settings
- softLight with dimmer function
- 2 x 3w LED Light
- Colour Temperature: 3500 K
- Efficient BLDC motor
- Twin channel high performance fan motor
- Automatic after running (10 minutes)
- Automatic intensive revert (6mins)
- Black grease filter
- Grease and charcoal filter saturation indicators
- easy to clean Inner frame
- 2 x metal grease filter cassettes

Design

- Black glass
- Chimney hood
- For wall mounted installation
- touchControl for extractor speeds and light
- Electronic control
- Rim ventilation
- Installation system: Wall fixing inclined/flat/cube

Performance/technical information

- Suitable for ducted and re-circulating operation
- In recirculation operation chimless use possible
- For recirculated extraction a recirculating kit or a CleanAir recirculation kit (accessory) is needed

- Max. extraction rate: 717 m³/h
- Noise level according to EN 60704-3 and EN 60704-2-13 exhaust air:
- Max. normal use: 57 dB(A) re 1 pW
- Intensive: 70 dB(A) re 1 pW
- Power rating: 150 W
- Light Intensity: 589 lux
- Electrical cable length 1.3 m
- Diameter pipe \varnothing 150 mm (\varnothing 120 mm enclosed)
- Dimensions exhaust air (HxWxD): 969-1239 x 890 x 263 mm
- Dimensions recirculating, chimney (HxWxD): 1029-1299 x 890 x 263 mm
- Dimensions recirculating, chimless (HxWxD): 500 mm x 890 x 263 mm
- Dimensions recirculating with CleanAir module (HxWxD):
- 1159 x 890 x 263 mm - mounting with outer chimney
- 1229-1499 x 890 x 263 mm - mounting with telescopic chimney
- Blower Efficiency Class: B*
- Lighting Efficiency Class: A*
- Grease Filtering Efficiency Class: B*
- Average Energy Consumption: 40 kWh/year*

Optional accessories

- Recirculating kit LZ10AXL50

* In accordance with the EU-Regulation No 65/2014

IQ700, Wall-mounted cooker hood, 90 cm, Clear glass black printed LC97FVW69B

Dimensioned drawings

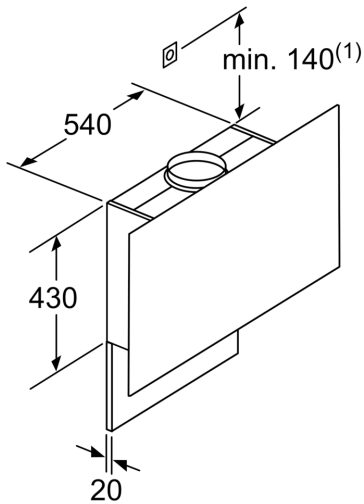

(1) Position of socket

Note the maximum thickness of the back panel.

measurements in mm

Measurements in mm

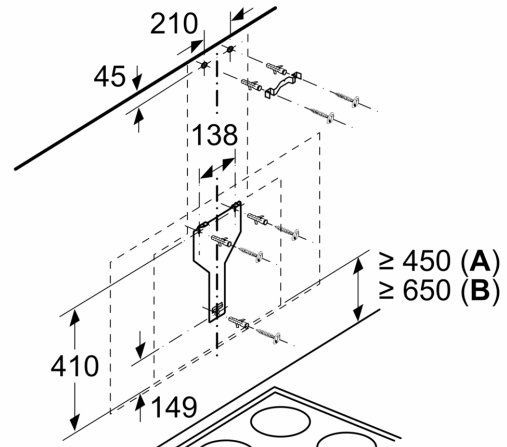

From upper edge of pan support

A: Electric
B: Gas

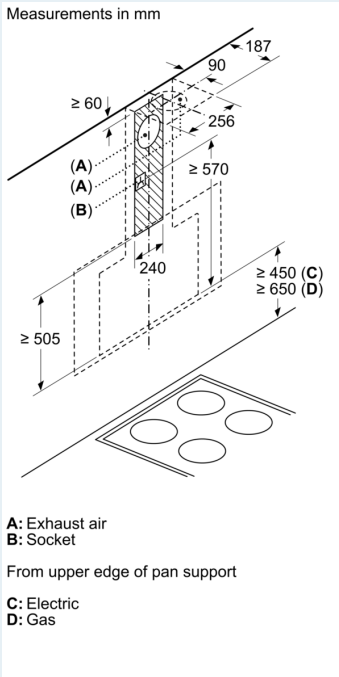

A: Exhaust air
B: Socket

From upper edge of pan support

C: Electric
D: Gas

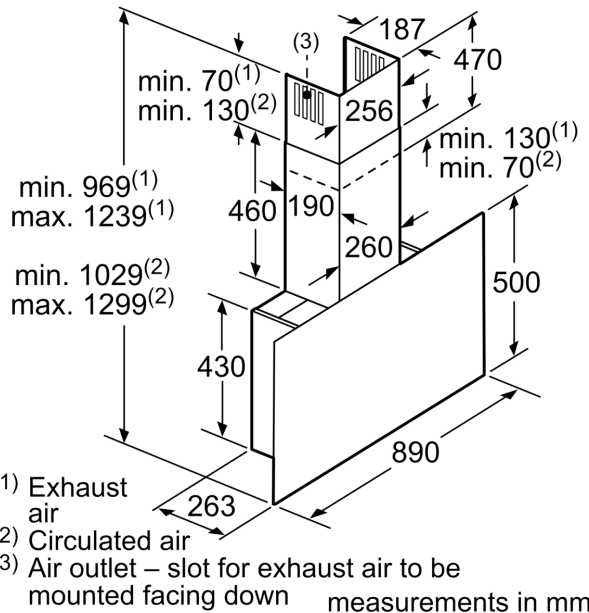

(1) Exhaust air
(2) Circulated air
(3) Air outlet – slot for exhaust air to be mounted facing down

measurements in mm

Dimensioned drawings

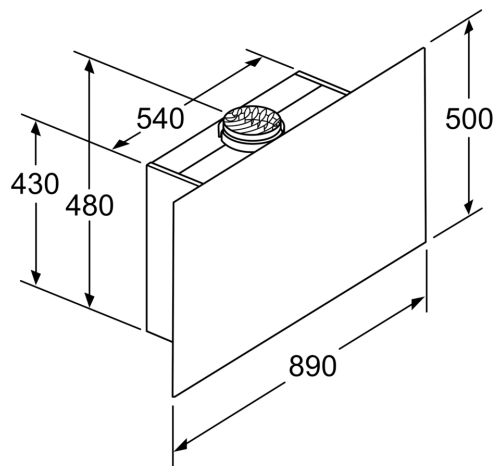

Appliance in circulated air mode
without duct
Circulated air set required
measurements in mm

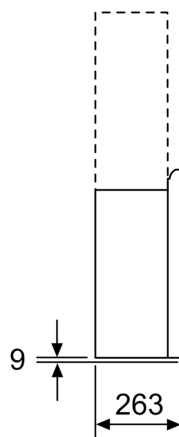

measurements in mm