

Series 2, built-in fridge-freezer with freezer at bottom, 177.2 x 54.1 cm, sliding hinge KIV87NSE0G



Optional accessories

- GSZB6B00 Box-in-Freezer-Box
- KSZB6R00 Bottle Rack
- KSZGGM00 Butter box

The spacious built-in fridge-freezer combination with LowFrost provides optimal food storage and ice formation is significantly reduced.

- **Eco Airflow:** maintains optimal air circulation and a constant temperature level throughout the cooling area.
- **LED lighting - with soft start, lasts for the lifetime of the appliance.**
- **Safety Glass Shelves:** safely store food in your fridge with stable, shatterproof glass shelves.

Technical Data

Energy Efficiency Class:	E
Average annual energy consumption in kilowatt hour per year (kWh/a):	216 kWh/annum
Sum of volume of frozen compartments:	70 l
Sum of volume of chill compartments:	200 l
Airborne acoustical noise emissions :	35 dB(A) re 1 pW
Airborne acoustical noise emission class:	B
Built-in / Free-standing:	Built-in
Door panel options:	Not possible
Height:	1772 mm
Width of the appliance:	541 mm
Depth:	548 mm
Min. required niche size for installation (HxWxD): 1775.0 x 560 x 550 mm	
Net weight:	50.7 kg
Fuse protection:	10 A
Door hinge:	Right reversible
Voltage:	220-240 V
Frequency:	50 Hz
Length electrical supply cord:	230.0 cm
Number of compressors:	1
Number of independent cooling systems:	1
Interior ventilator:	No
Reversible Door Hinge:	Yes
Number of Adjustable Shelves in fridge compartment:	4
Shelves for Bottles:	No
Frost free system:	No
Installation typology:	N/A



Series 2, built-in fridge-freezer with freezer at bottom, 177.2 x 54.1 cm, sliding hinge KIV87NSE0G

Dimension and installation
Additional features

The spacious built-in fridge-freezer combination with LowFrost provides optimal food storage and ice formation is significantly reduced.

- easy Installation

Performance and Consumption

- EU19_EEK_D: E
- Total Volume : 270 l
- Annual Energy Consumption: 216 kWh/a
- EU19_Fast freezer facility_D: yes
- Noise Level : 35 dB

Functions

- Bright interior LED fridge light

Design features

- LED electronic control
- SuperCool function
- SuperFreeze functions with automatic deactivation
- Optical and acoustical door open warning

Design features

- Net Fridge Volume : 200 l
- 5 safety glass shelves in fridge compartment of which 4 are height adjustable
- 4 door bins

Freshness System

- 1 MultiBox - Transparent drawer with a rippled bottom, ideal for storing fruits and vegetables.

Food freshness system

- Net Freezer Volume : 70 l
- Freezing capacity 24h : 3.2 kg
- Temperature rise time : EU19_Temperature rise time_D: 12 H
- 2 freezer drawers

Dimension and installation

- Dimensions: 177.2 cm H x 54.1 cm W x 54.8 cm D
- Niche Dimensions: 177.5 cm H x 56 cm W x 55 cm D

Key features - Fridge section

- Right hinged door, reversible door
- Climate Class: SN-ST
- 220 - 240 V
- Length of power cord:230 cm

Key features - Freezer section

- 3 x egg tray, 1 x ice cube tray

Country Specific Options

- Based on the results of the standard 24-hour test. Actual consumption depends on usage/position of the appliance.

Design features

**Series 2, built-in fridge-freezer with
freezer at bottom, 177.2 x 54.1 cm,
sliding hinge
KIV87NSE0G**

measurements in mm

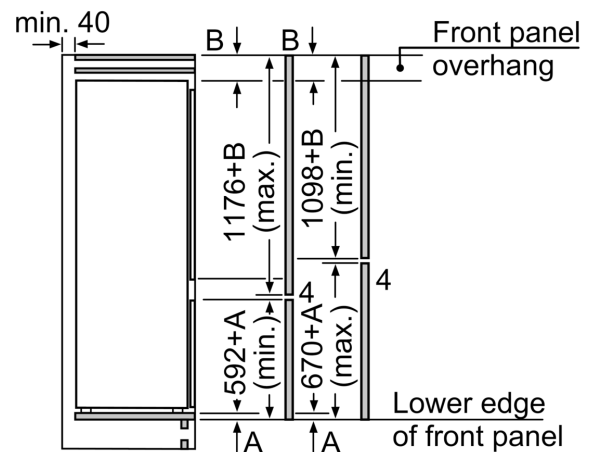
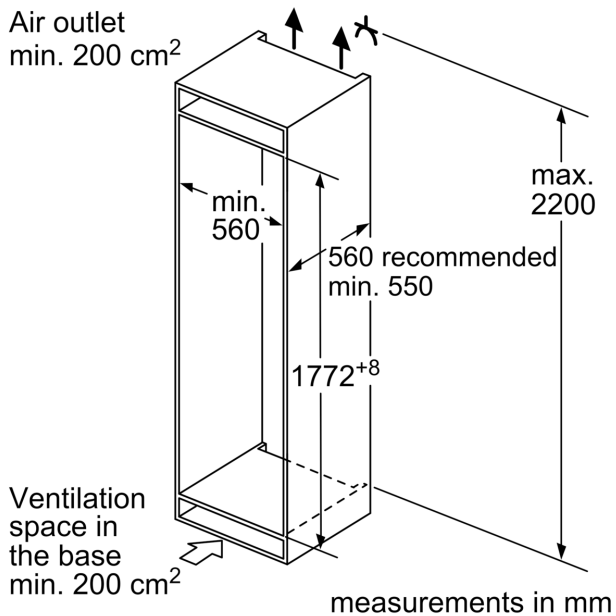
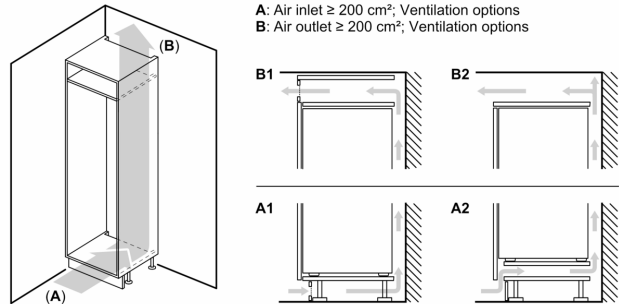
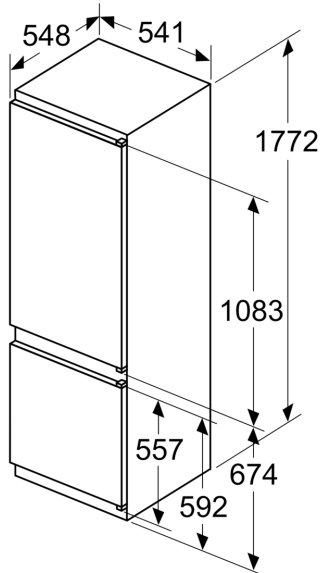

The specified unit door dimensions
are valid for a door gap of 4 mm.

measurements in mm