

**Series 2, built-in fridge-freezer with freezer at bottom, 177.2 x 54.1 cm, sliding hinge
KIN86NSE0G**



KSZB6R00 Bottle Rack
KSZGGM00 Butter box

The spacious built-in fridge-freezer combination with NoFrost provides optimal food storage and ice formation is no longer an issue.

- **MultiBox XXL:** extra-large drawer for your fruit and vegetables.
- **NoFrost:** never defrost again, thanks to perfect protection from ice formation - that saves time and effort.
- **Eco Airflow:** maintains optimal air circulation and a constant temperature level throughout the cooling area.
- **LED lighting - with soft start, lasts for the lifetime of the appliance.**
- **Safety Glass Shelves:** safely store food in your fridge with stable, shatterproof glass shelves.

Energy Efficiency Class: E
 Average annual energy consumption in kilowatt hour per year (kWh/a): 234 kWh/annum
 Sum of volume of frozen compartments: 76 l
 Sum of volume of chill compartments: 184 l
 Airborne acoustical noise emissions : 35 dB(A) re 1 pW
 Airborne acoustical noise emission class: B
 Built-in / Free-standing: Built-in
 Door panel options: Not possible
 Height: 1772 mm
 Width of the appliance: 541 mm
 Depth: 548 mm
 Min. required niche size for installation (HxWxD): 1775.0 x 560 x 550 mm
 Net weight: 51.2 kg
 Fuse protection: 10 A
 Door hinge: Right reversible
 Voltage: 220-240 V
 Frequency: 50 Hz
 Length electrical supply cord: 230.0 cm
 Number of compressors: 1
 Number of independent cooling systems: 1
 Interior ventilator: No
 Reversible Door Hinge: Yes
 Number of Adjustable Shelves in fridge compartment: 3
 Shelves for Bottles: No
 Frost free system: Fridge and freezer
 Installation typology: N/A



Series 2, built-in fridge-freezer with freezer at bottom, 177.2 x 54.1 cm, sliding hinge KIN86NSE0G

Additional features
Design features
Dimension and installation

The spacious built-in fridge-freezer combination with NoFrost provides optimal food storage and ice formation is no longer an issue.

Performance and Consumption

- EU19_EEK_D: E
- Total Volume : 260 l
- Annual Energy Consumption: 234 kWh/a
- EU19_Fast freezer facility_D: yes
- Noise Level : 35 dB

Functions

- Bright interior LED fridge light

Design features

- LED electronic control
- SuperCool function
- Height adjustable front feet
- Automatic defrost fridge
- Optical and acoustic door open alarm

Design features

- Net Fridge Volume : 184 l
- 4 safety glass shelves of which 3 are height adjustable
- Door shelves in fridge door: 1 large and 2 small

Freshness System

- 1 MultiBox - Transparent drawer with a rippled bottom, ideal for storing fruits and vegetables.

Food freshness system

- Net Freezer Volume : 76 l
- Freezing capacity 24h : 4 kg
- Temperature rise time : EU19_Temperature rise time_D: 10 H
- NoFrost freezer, never have to defrost ever again
- SuperFreeze functions with automatic deactivation
- 3 freezer drawers

Dimension and installation

- Dimensions: 177.2 cm H x 54.1 cm W x 54.8 cm D
- Niche Dimensions: 177.5 cm H x 56 cm W x 55 cm D

Key features - Fridge section

- Right hinged door, reversible door
- 220 - 240 V
- Length of power cord: 230 cm
- Climate Class: SN-ST

Country Specific Options

- Based on the results of the standard 24-hour test. Actual consumption depends on usage/position of the appliance.

Key features - Freezer section

- 3 x egg tray, 1 x ice cube tray

**Series 2, built-in fridge-freezer with
freezer at bottom, 177.2 x 54.1 cm,
sliding hinge
KIN86NSE0G**

measurements in mm

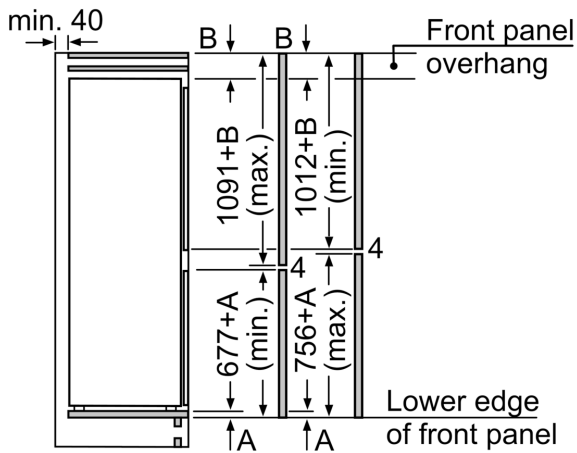
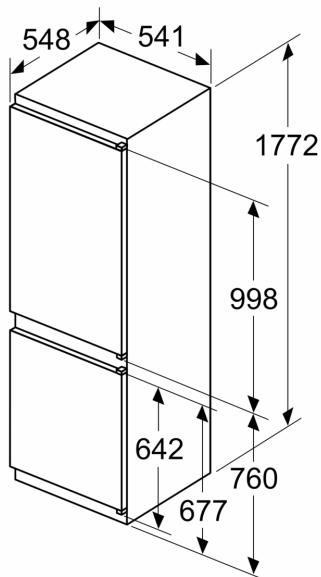

The specified unit door dimensions are valid for a door gap of 4 mm.

measurements in mm

