

**iQ100, built-in fridge-freezer with
freezer at bottom, 177.2 x 54.1 cm,
sliding hinge
KI38VX22GB**



built-in fridge freezer for crisper fruit and vegetables thanks to the Fresh Box with wavy bottom.

- ✓ The fruit and vegetables stay crispy in the Fresh Box with wavy bottom.
- ✓ The safetyGlass shelves are of extra strong, easy-cleaning safety glass.
- ✓ Fresh – Convenient storage for your fruit and vegetables.
- ✓ freshSense: sensors that keep the inside temperature steady for longer food freshness

Features

Technical Data

Energy Efficiency Class: G
 Average annual energy consumption in kilowatt hour per year (kWh/a):
 341 kWh/annum
 Sum of volume of frozen compartments: 64 l
 Sum of volume of chill compartments: 217 l
 Airborne acoustical noise emissions : 40 dB(A) re 1 pW
 Airborne acoustical noise emission class: C
 Built-in / Free-standing: Built-in
 Door panel options: Not possible
 Width of the appliance: 541 mm
 Depth: 545 mm
 Required niche size for installation (HxWxD): 1775.0 x 562.0 x 550 mm
 Net weight: 56.913 kg
 Connection Rating: 90 W
 Fuse protection: 13 A
 Door hinge: Right reversible
 Voltage: 220-240 V
 Frequency: 50 Hz
 Approval certificates: CE, VDE
 Length electrical supply cord: 230 cm
 Storage Period in Event of Power Failure (h): 7 h
 Number of compressors: 1
 Number of independent cooling systems: 1
 Interior ventilator: No
 Reversible Door Hinge: Yes
 Number of Adjustable Shelves in fridge compartment: 4
 Shelves for Bottles: No
 Frost free system: No
 Installation typology: Full-integrated
 Type of hinge: Follow-door

Included accessories

1 x butter dish



**iQ100, built-in fridge-freezer with
freezer at bottom, 177.2 x 54.1 cm,
sliding hinge
KI38VX22GB**

Features

Design features

- Sliding hinge - Easy installation
- Right hinged door, door reversible
- Electronic control (LED chain)

Food freshness system

- 1 compressor/1 cooling circuit

Key features - Fridge section

- 5 safety glass shelves in fridge compartment of which 4 are height adjustable
- 1 vegetable/salad container
-

Key features - Freezer section

- Manual defrost freezer
- 3 freezer drawers

Dimension and installation

- Connection value 90 W
- 220 - 240 V
- Dimensions: 177.2 cm H x 54.1 cm W x 54.5 cm D
- Niche Dimensions: 177.5 cm H x 56.2 cm W x 55 cm D

Performance and Consumption

- EU19_EEK_D: G
- Total Volume : 281 l
- Net Fridge Volume : 217 l
- Net Freezer Volume : 64 l
- Annual Energy Consumption: 341 kWh/a
- Climate Class: SN-ST
- EU19_Fast freezer facility_D: yes
- Noise Level : 40 dB
- Temperature rise time : EU19_Temperature rise time_D: 7 H

**iQ100, built-in fridge-freezer with
freezer at bottom, 177.2 x 54.1 cm,
sliding hinge
KI38VX22GB**

Dimensioned drawings

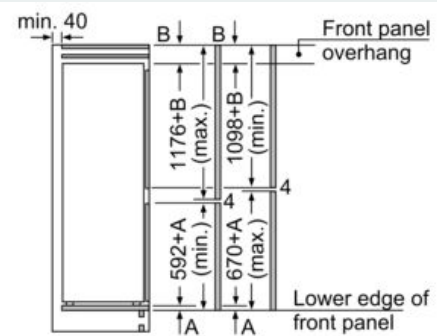
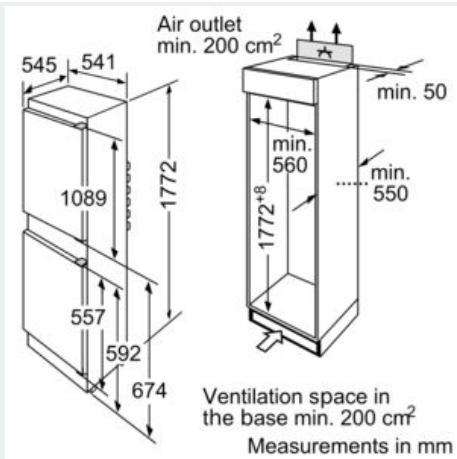

The specified unit door dimensions are valid for a door gap of 4 mm.

measurements in mm

