

**IQ100, built-in fridge-freezer with freezer at bottom, 193.5 x 69.1 cm, sliding hinge KB96NNSE0**



Built-in fridge freezer with 45 percent extra space and hyperFresh <0°C>: ideal storage conditions for all your food and XXL capacity to shop in bulk.

- ✓ Large volume – 45% more space for your entire weekly shop.
- ✓ hyperFresh – The extra-large drawer for your fruit and vegetables.
- ✓ LED light – Even lighting throughout the inside of your fridge to keep everything in view.
- ✓ noFrost – Never defrost your freezer again.
- ✓ doorAlarm – A gentle reminder to keep the door closed.



Energy Efficiency Class: .....	E
Average annual energy consumption in kilowatt hour per year (kWh/a): .....	256 kWh/annum
Sum of volume of frozen compartments: .....	98 l
Sum of volume of chill compartments: .....	285 l
Airborne acoustical noise emissions : .....	34 dB(A) re 1 pW
Airborne acoustical noise emission class: .....	B
Built-in / Free-standing: .....	Built-in
Door panel options: .....	Not possible
Height: .....	1935 mm
Width of the appliance: .....	691 mm
Dimensions: .....	548 mm
Min. required niche size for installation (HxWxD):	1940 x 710 x 560 mm
Weight: .....	65.9 kg
Fuse protection: .....	10 A
Door hinge: .....	Right reversible
Nominal power: .....	220-240 V
Frequency: .....	50 Hz
Length electrical supply cord: .....	230.0 cm
Number of compressors: .....	1
Number of independent cooling systems: .....	2
Interior ventilator: .....	No
Reversible Door Hinge: .....	Yes
Number of Adjustable Shelves in fridge compartment: .....	4
Shelves for Bottles: .....	No
Frost free system: .....	Fridge and freezer
Installation type: .....	N/A

KSZGGM00 Butter box



## IQ100, built-in fridge-freezer with freezer at bottom, 193.5 x 69.1 cm, sliding hinge KB96NNSEO

- noFrost freezer, Built-in fridge freezer
- Sliding hinge - Easy installation, softClosing door: No

### Performance and Consumption

- EU19\_EEK\_D: E
- Total Volume : 383 l
- Annual Energy Consumption: 256 kWh/a
- Noise Level : 34 dB

### Functions

- LED fridge light with Soft Start
- Built-in fridge freezer

### Design features

- noFrost freezer, never have to defrost ever again
- Heavy load hinge set
- EU19\_Fast freezer facility\_D: yes
- Home Connect: iService Remote, Remote Monitoring and Control with Wi-Fi connectivity
- Electronic control (2 LED chains)
- Twin evaporators allows independent temperature control and ensures there is no transference of humidity between the fridge and freezer cavity.
- superCool function with automatic deactivation
- acoustic for Fridge and Freezer, acoustic alarm, Optical and acoustical door open warning system
- Automatic defrost in fridge section

### Design features

- Net Fridge Volume : 285 l
- 5 safety glass shelves of which 4 are height adjustable
- Door shelves in fridge door: 1 large and 3 small

### Freshness System

- 1 hyperFresh box with integrated humidity control

### Food freshness system

- Net Freezer Volume : 98 l
- Freezing capacity 24h : 9.5 kg
- Temperature rise time : EU19\_Temperature rise time\_D: 12 H
- 3 freezer drawers

### Dimension and installation

- Dimensions: 193.5 cm H x 69.1 cm W x 54.8 cm D
- Niche Dimensions: 194 cm H x 71 cm W x 56 cm D

### Key features - Fridge section

- Right hinged door, door reversible
- Height adjustable front feet
- Length of power cord:230 cm
- Climate Class: SN-ST
- 220 - 240 V

### Key features - Freezer section

- 3 x egg tray, 2 x ice cube tray

### Country Specific Options

- Based on the results of the standard 24-hour test. Actual consumption depends on usage/position of the appliance.

### Design features

### Dimension and installation

### Additional features

- none

**IQ100, built-in fridge-freezer with  
freezer at bottom, 193.5 x 69.1  
cm, sliding hinge  
KB96NNSE0**

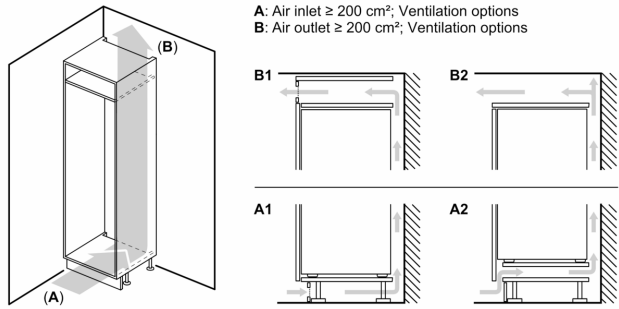

Measurements in mm

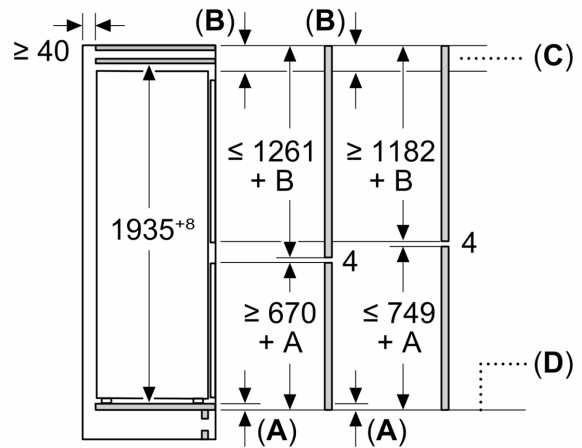

C: Front panel overhang

D: Lower edge of front panel

Measurements in mm

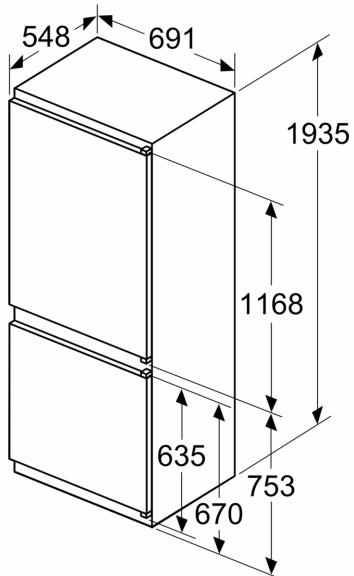

Measurements in mm

