

**iQ500, built-in microwave, 59 x 38 cm,
Stainless steel
HF24M564B**



- ✓ Automatic programs ensure best results.
- ✓ 900 Watts maximum: ideal for heating liquids
- ✓ The side-opening hinged door: ideal for elevated installation.

Features

Technical Data

Type of micro-wave oven : MW only
 Type of control : Electronic
 Color / Material Front : Stainless steel
 Cavity dimensions (mm) : 208.0 x 328.0 x 369.0
 Approval certificates : CE
 Length electrical supply cord (cm) : 130
 Net weight (kg) : 18.298
 Gross weight (kg) : 20.1
 EAN code : 4242003658581
 Maximum micro-wave power (W) : 900
 Connection Rating (W) : 1450
 Fuse protection (A) : 10
 Voltage (V) : 230-240
 Frequency (Hz) : 50
 Plug type : GB plug
 Cavity dimensions (mm) : 208.0 x 328.0 x 369.0



**iQ500, built-in microwave, 59 x 38 cm,
Stainless steel
HF24M564B**

Features

Design

- Electronic oven clock timer
- Touch control, Stainless steel control dial, Retractable control dial
- 31.5 cm Glass turntable
- White display with blue indicator lights
- Open Door button
- Left hinged door

Key Information

- Electronic control

Features

- 1 interior light
- Stainless steel interior

Programmes/functions

- microwave
- 4 weight automatic defrost programmes
- 1 memory function

Performance/technical information

- Oven capacity: 25 litres
- Installation in tall housing
-
- Installation in base unit/under work surface
- 5 microwave power levels
- Maximum microwave power level: 900 W
- Connected load 1.45 KW
- 130 cm power cable: UK 3 pin plug

Standard accessories

**iQ500, built-in microwave, 59 x 38 cm,
Stainless steel
HF24M564B**

Dimensioned drawings

Microwave,
corner installation

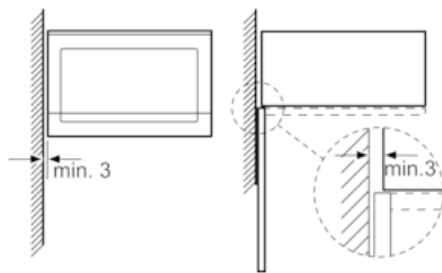

Measurements in mm

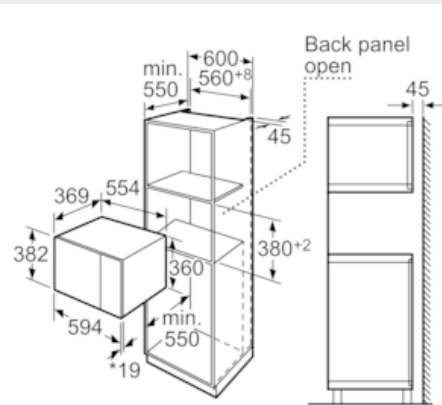

* 20 mm for metal fascias

measurements in mm

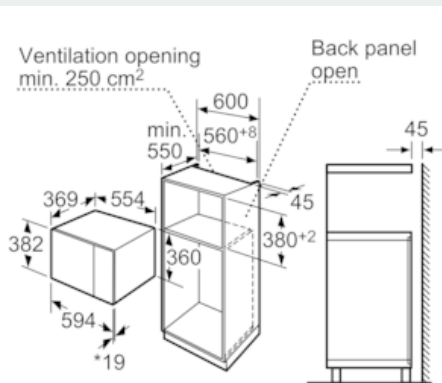

* 20 mm for metal fascias

measurements in mm