



**iQ500, built-in microwave, 60 x 38 cm,
Black
HF15M664B**



38cm high built-in, frameless microwave for fast defrosting, reheating or preparation of dishes.

- ✓ Automatic programs ensure best results.
- ✓ The side-opening hinged door: ideal for elevated installation.

Features

Technical Data

Type of micro-wave oven : MW only
Type of control : Electronic
Color / Material Front : Black
Dimensions : 382 x 594 x 317 mm
Cavity dimensions : 201.0 x 308.0 x 282.0 mm
Length electrical supply cord : 130 cm
Net weight : 16.4 kg
Gross weight : 18.1 kg
EAN code : 4242003658482
Maximum micro-wave power : 800 W
Connection Rating : 1270 W
Fuse protection : 10 A
Voltage : 230-240 V
Frequency : 50 Hz
Plug type : GB plug
Cavity dimensions : 201.0 x 308.0 x 282.0 mm





**iQ500, built-in microwave, 60 x 38 cm,
Black
HF15M664B**

Features

Features:

- Left hinged door
- User-friendly electronics with push-buttons and pop-out control.
- Comfort:
 - 4 weight automatic defrost programmes
 - 1 recipe memory setting
 - Electronic oven clock timer

Features

- Maximum microwave power level: 800 W
- 5 microwave power levels
- Maximum microwave power level: 800 W

Performance/technical information

- Installation 60 cm wide wall unit, Installation in tall housing
-
- Oven capacity: 20 litres
- 25.5 cm Glass turntable
- Connected load 1.27 KW
- 130 cm power cable: UK 3 pin plug



**iQ500, built-in microwave, 60 x 38 cm,
Black
HF15M664B**

Dimensioned drawings

Microwave,
corner installation

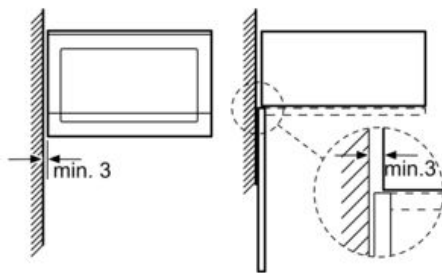

Measurements in mm

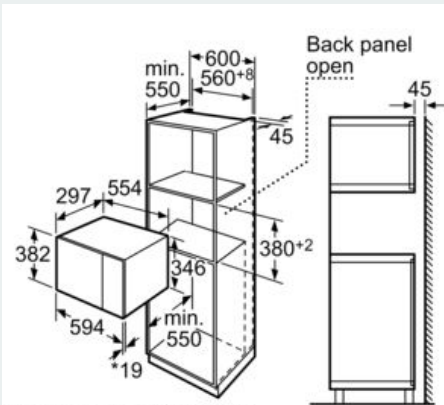

* 20 mm for metal fascias

measurements in mm

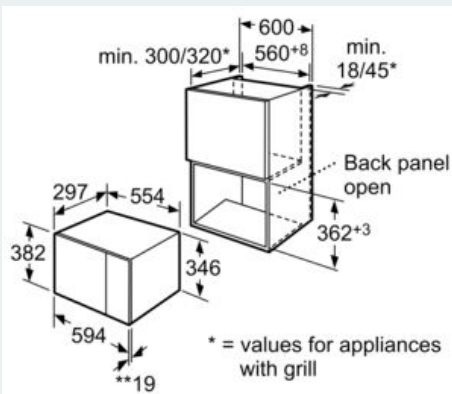

* = values for appliances
with grill

** 20 mm for metal fascias

measurements in mm