

**Adapter duct, Ø 150 mm, 90 °,
round-flat
HEZ9VDS11**

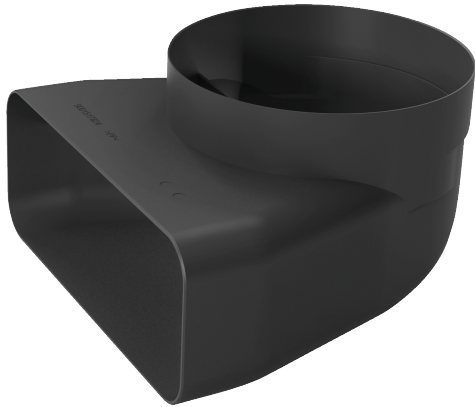

- Flat to round converter with integrated 90° bend for appliances with vertical round air outlet (e.g. Glassdraft)
- 90° round-flat adapter element (male)
- Aerodynamically optimised design to minimise pressure loss and maximise air flow rate. Easy-to-cut & easy-to-connect via the female connector sleeve element.
- The element complies with the Needle Flame Test (according to IEC 60695-11-5) & the V2 flammability class (according to UL94).

Technical Data

Dimensions of the packed product (HxWxD): 190 x 235 x 220 mm
Pallet dimensions: 175.0 x 80.0 x 120.0
Quantity per packing unit: 1
Standard number of units per pallet: 128
Net weight: 0.3 kg
Gross weight: 0.5 kg
EAN code: 4242005254248



**Adapter duct, \varnothing 150 mm, 90 °,
round-flat
HEZ9VDSI1**

measurements in mm

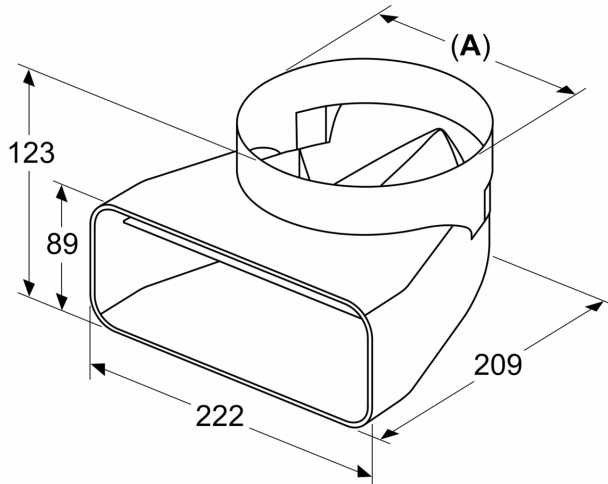

A: \varnothing 152.5