

IQ700, Induction hob with integrated ventilation system, 80 cm, flush mount EX807LX33E

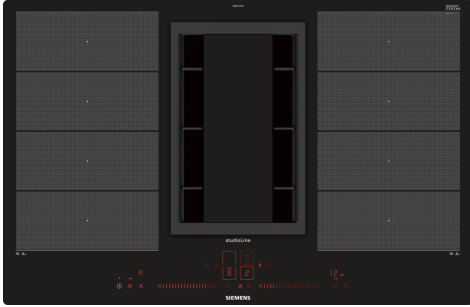

A



Included accessories

1 x wireless temperature sensor for cooktop

Optional accessories

HZ381401 Exhaust kit, HZ381501 Recirculating kit, HZ381700 Recirculation filter, HZ390011 Stainless Steel roaster with glass lid, HZ390012 Steaming Rack for Stainless Steel roaster, HZ390090 Wok Set consisting of 3 items, HZ390210 System pan diameter 15 cm, HZ390220 System pan diameter 19 cm, HZ390230 System pan diameter 21cm, HZ9SE030 Set of 2 pots and 1 pan, HZ39050 Wireless temperature sensor for cooktop, HZ390512 Teppan Yaki (large), HZ390522 Griddle Plate

Induction hob with integrated ventilation unit.

- ✓ flexInduction – Smart cooking zone that adapts to your cookware.
- ✓ Dual light slider – Just touch and slide to control your hob.
- ✓ climateControl Sensor – Monitors steam and smells, adjusts the power level automatically.
- ✓ Precisely maintaining the chosen temperature to avoid overboiling – cookingSensor Plus.
- ✓ fryingSensor Plus – No more burning or scorching your meals.

Features

Technical Data

Product name/family: Cooking zone ceramic
 Built-in / Free-standing: Built-in
 Energy input: Electric
 Width of the appliance: 792 mm
 Dimensions: 204 x 792 x 512 mm
 Dimensions of the packed product (HxWxD): ... 330 x 760 x 940 mm
 Weight: 25.1 kg
 Gross weight: 31.4 kg
 Residual heat indicator: Separate
 Location of control panel: Front
 Basic surface material: Ceramic
 Color of surface: Black
 Length electrical supply cord: 110.0 cm
 Sealed Burners: No
 Heating with booster: All
 Power of 2nd heating element (kW): 3.3 kW
 Number of speed settings: 9-stage + intensive
 Maximum output air extraction: 551 m³/h
 Boost position output recirculating: 630.0 m³/h
 Maximum output recirculating air: 557 m³/h
 Boost position air extraction: 698 m³/h
 Noise level: 70 dB(A) re 1 pW
 Odour filter: No
 Ventilation type: Convertible
 Grease filter type: Kasette
 Nominal power: 220-240 V
 Frequency: 50; 60 Hz
 Included accessories: 1 x wireless temperature sensor for cooktop
 Delay Shut off modes: 30 min



IQ700, Induction hob with integrated ventilation system, 80 cm, flush mount EX807LX33E

Features

Design

- Induction hob with extractor, autarkic
- studioLine Flush Fitting
- 792 mm

Control

- Dual lightSlider
- fryingSensor plus with 5 temperature settings
- 1 x cookingSensor Plus included

Special features

- 2 flexInduction zones
- 4 induction cooking zones
- powerMove plus
- reStart function
- Timer for all zones
- Acoustic Signal Count up timer
- Keep warm function
- 17 power levels
- Power boost setting
- panBoost
- Energy Consumption Display

Performance/technical information

- High-performance blower, Efficient BLDC-technology
- Suitable for ducted or re-circulated extraction (Accessory is respectively needed)
- Fully-automatic extraction functionality with Automatic Air Sensor
- 9 speeds plus 1 intensive
- Automatic 30 minutes after running
- Cast-iron air inlet grid, heat resistant, dishwasher safe
- Saturation indicator for cleanAir odour filter
- Removable and detachable grease filter and liquid collector unit, dishwasher safe
- - integrated stainless steel grease filters, dishwasher safe - condensate and liquid collector unit; ca. 200ml capacity; dishwasher safe
- Liquid spillover safety tank, ca. 2000ml capacity, Twist-off lock, dishwasher safe
- For ducted extraction kit, accessory HZ381401 needed
- For recirculated extraction cleanAir kit, accessory HZ381501 needed

Safety Features

- Automatic pan recognition
- Automatic safety switch off Control panel lock Control panel pause
- 2 stage residual heat indicators
- Main on/off switch

Technical information

- Cooking zones: 1 x Ø 400 mmx240 mm, 3.3 KW (max. Power levels 3.7 KW) Induction or 2 x Ø 200 mm, 2.2 KW (max. Power levels 3.7

KW) Induction; 1 x Ø 400 mmx240 mm, 3.3 KW (max. Power levels 3.7 KW) Induction or 2 x Ø 200 mm, 2.2 KW (max. Power levels 3.7 KW) Induction

- Energy Efficiency Class: A (at a range of energy efficiency classes from A+++ to D)
- Average Energy Consumption: 53.5 kWh/year
- Blower Efficiency Class: A
- Grease Filtering Efficiency Class: B
- Extraction rate:
 - - min. normal setting 169 m3/h
 - - max. normal setting 551 m3/h
 - - Boost/Intensive setting 698 m3/h
- Noise min./max. Normal Level: 39/69 dB
- Noise level in ducted extraction :
 - - min. normal setting 42 dB(A) re 1 pW (31dB(A) re 20 µPa sound pressure)
 - - max. normal setting 70 dB(A) re 1 pW (59dB(A) re 20 µPa sound pressure)
 - - Boost/Intensive setting 75 dB(A) re 1 pW (64 dB(A) re 20 µPa sound pressure)
- Performance in re-circulated extraction:
 - - min. normal setting 139 m3/h
 - - max. normal setting 557 m3/h
 - - Boost-/Intensive setting 630 m3/h
- Noise level in re-circulated extraction:
 - - min. normal setting 42 dB(A) re 1 pW (31dB(A) re 20 µPa sound pressure)
 - - max. normal setting 74 dB(A) re 1 pW (62dB(A) re 20 µPa sound pressure)
 - - Boost-/Intensive setting 75 dB(A) re 1 pW (62 dB(A) re 20 µPa sound pressure)
- Grease filter efficiency: 90 %
- Odour reduction rate: 85 %
- Connection cable (1.1 m) with cable
- Large-scale stainless-steel grease filters with 12 layers for high grease filtration efficiency
- Connected load: 7.4 KW
- Cable included in packaging

Installation Advice

- Base cupboard width: min. 80 cm.
- Min. worktop thickness: 30 mm (Installation in thinner worktops is also possible with the spare part: 626792)
- Worktop depth: min. 60 cm (with shortened drawers), max. drawer's depth can be used starting with a worktop depth of 70 cm.
- Immersion depth: 20.4 cm
- Modules for ducted extraction or re-circulated extraction must be ordered separately as special accessory.
- Installation measurements: 780 mmx500 mm

Features

--	--

**IQ700, Induction hob with integrated ventilation system, 80 cm, flush mount
EX807LX33E**

Dimensioned drawings

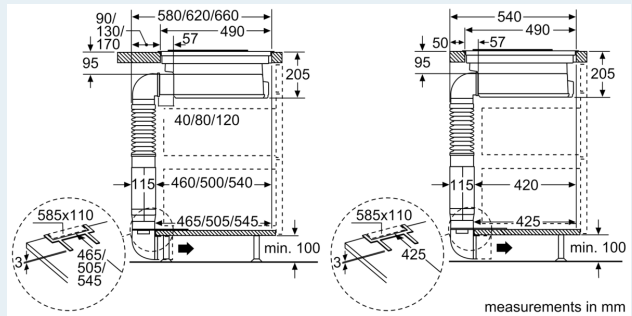
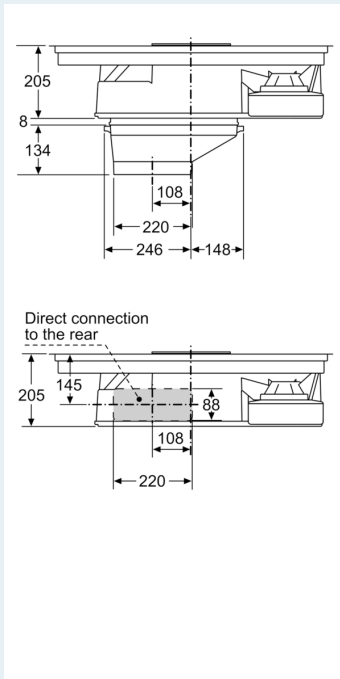
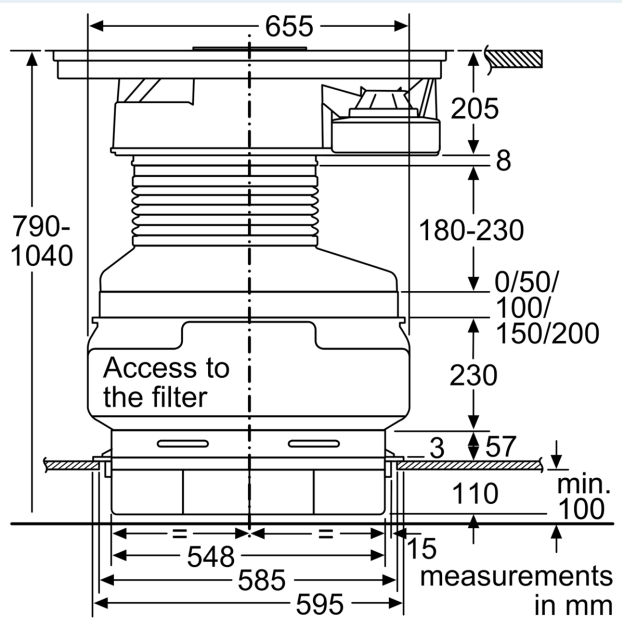
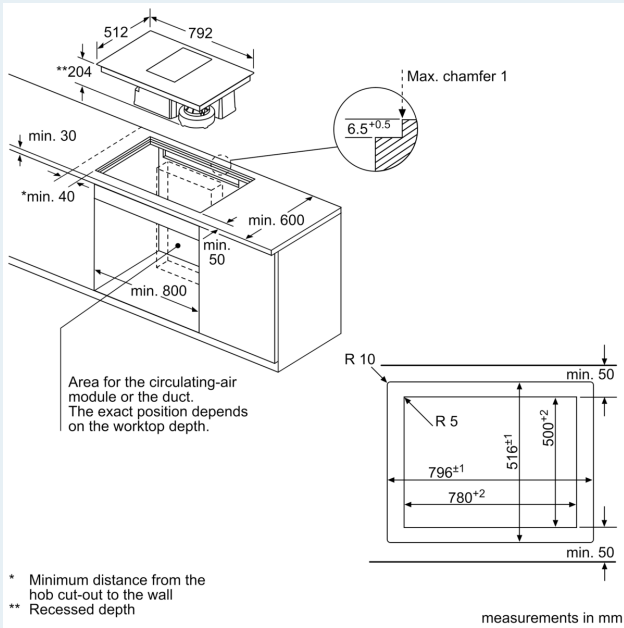

Dimensioned drawings

