

## iQ100, induction hob, 80 cm, EH877FVB1E

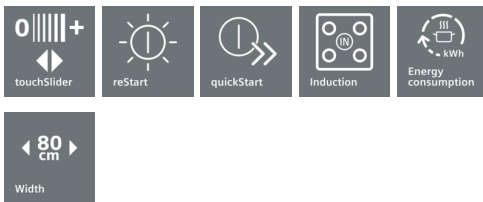

Induction hob with innovative features that enable highly flexible cooking in any situation.

- ✓ The touchSlider allows the hob temperature to be controlled by entering it directly or by moving the slider with a single finger.
- ✓ Shorter heating times with up to 50% more power thanks to the powerBoost function.
- ✓ Safely shuts off the cooking zone - Timer with switch-off function.

### Features

#### Technical Data

Product name/family : Cooking zone ceramic  
 Construction type : Built-in  
 Energy input : Electric  
 Total number of positions that can be used at the same time : 5  
 Required niche size for installation (HxWxD) : 51 x 750-780 x 490-500  
 Appliance Width (mm) : 812  
 Dimensions of the product (mm) : 51 x 812 x 520  
 Dimensions of the packed product (HxWxD) (mm) : 126 x 953 x 603  
 Net weight (kg) : 15.263  
 Gross weight (kg) : 16.8  
 Residual heat indicator : Separate  
 Location of control panel : Hob front  
 Basic surface material : Ceramic  
 Color of surface : Black  
 Approval certificates : AENOR, CE  
 Length electrical supply cord (cm) : 110  
 EAN code : 4242003716427  
 Electrical connection rating (W) : 7400  
 Voltage (V) : 220-240  
 Frequency (Hz) : 50; 60



### Optional accessories

HZ9SE030 Set of 2 pots and 1 pan

## iQ100, induction hob, 80 cm, EH877FVB1E

### Features

#### Control:

- touchSlider control

#### Special features

- 5 induction cooking zones
- reStart function
- Timer for all zones Acoustic Signal
- 17 power levels
- Power boost setting
- Energy Consumption Display

#### Safety Features

- Automatic pan recognition Automatic safety switch off Control panel lock Control panel pause
- 2 stage residual heat indicators
- Main on/off switch

#### Power and size:

- Cooking zones: 1 x Ø 180 mm, 1.8 KW (max. Power levels 3.1 KW) Induction; 1 x Ø 145 mm, 1.4 KW (max. Power levels 2.2 KW) Induction; 1 x Ø 240 mm, 2.2 KW (max. Power levels 3.7 KW) Induction; 1 x Ø 145 mm, 1.4 KW (max. Power levels 2.2 KW) Induction; 1 x Ø 210 mm, 2.2 KW (max. Power levels 3.7 KW) Induction

#### Technical information

- Installation measurements: 750 mmx490 mm
- Min. worktop thickness: 20 mm
- Connected load: 7.4 KW
- Connection cable 110 cm
- Cable included in packaging

**iQ100, induction hob, 80 cm,  
EH877FVB1E**

Dimensioned drawings

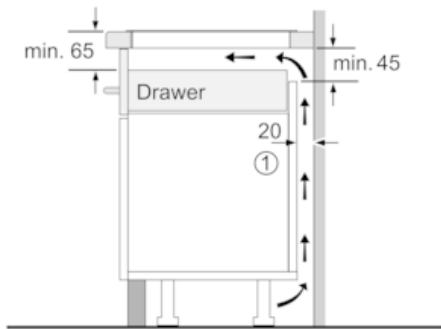

① Ventilation gap must be present.

Measurements in mm

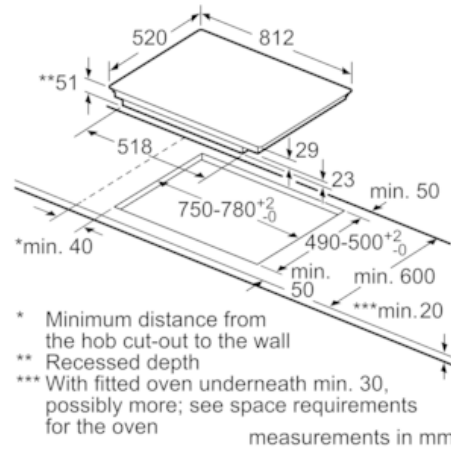

\* Minimum distance from the hob cut-out to the wall  
 \*\* Recessed depth  
 \*\*\* With fitted oven underneath min. 30, possibly more; see space requirements for the oven  
 measurements in mm

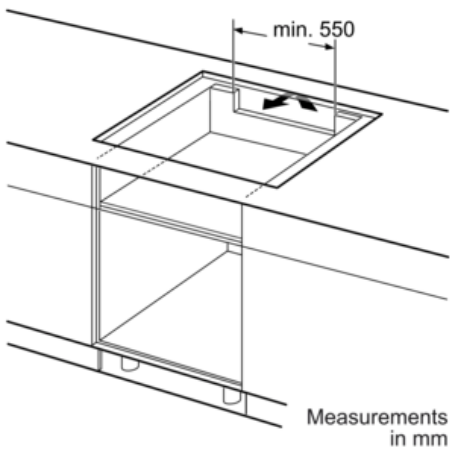

Measurements in mm

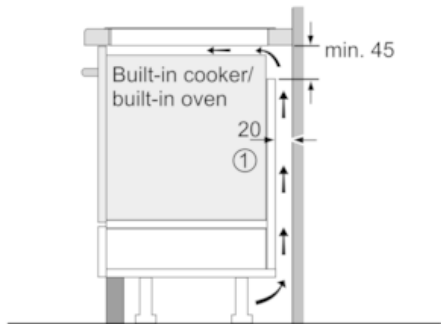

① Ventilation gap must be present

All measurements in mm