

**Serie | 2**
**Box style hood  
DWB064W50B Brushed steel**

**D**
**Wall mounted chimney hoods add style and sophistication to the kitchen and give you complete freedom in your kitchen planning.**

- An impressive extraction rate of 460 m<sup>3</sup>/h ensures this hood will have your kitchen odour free in no time.
- Halogen lighting provides energy efficient and bright lighting of the hob area.

**Technical Data**

Color chimney :	Stainless steel
Typology :	Chimney
Approval certificates :	CE, VDE
Length electrical supply cord (cm) :	130
Height of the chimney (mm) :	582-894/582-1004
Height of product, without chimney (mm) :	60
Minimum distance above an electric hob :	550
Minimum distance above a gas hob :	650
Net weight (kg) :	15.224
Type of control :	mechanical
Number of speed settings :	3
Maximum output air extraction (m <sup>3</sup> /h) :	460
Maximum output recirculating air (m <sup>3</sup> /h) :	290
Number of lights :	2
Noise level (dB(A) re 1 pW) :	62
Diameter of air outlet (mm) :	120 / 150
Grease filter material :	Washable aluminium
EAN code :	4242002779430
Connection Rating (W) :	170
Current (A) :	10
Voltage (V) :	220-240
Frequency (Hz) :	50; 60
Plug type :	GB plug
Installation typology :	Wall-mounted

**Optional accessories**

- DHZ1225 : Chimney extension 1000 mm
- DHZ1235 : Chimney extension 1500 mm
- DHZ5326 : Active carbon filter
- DSZ5201 : CleanAir active carbon filter spare part
- DSZ6200 : CleanAir Recirculation Kit
- DZZ0XX0P0 : CleanAir act.carbon filter regenerative



4 242002 779430

## Serie | 2 Hoods

### Box style hood

#### DWB064W50B Brushed steel

**Wall mounted chimney hoods add style and sophistication to the kitchen and give you complete freedom in your kitchen planning.**

---

#### Key features

- Electronic power level display
- Charcoal filter saturation indicator

#### Design

- 60 cm wide
- Designed for wall mounted installation
- Height adjustable chimney sections

#### Features

- Rocker switch control for extractor speeds and light
- 3 power levels
- 2 x halogen lights
- Removable metal grease filters
- Filter cover stainless steel, perforated and dishwasher safe
- Removable multi-zone extraction filter box
- 2 metal grease filter cassettes
- Removable metal grease filters
- For recirculated extraction recirculating kit or CleanAir recirculating kit (accessory) needed
- 3 power levels

#### Performance/technical information

- Suitable for ducted or recirculating operation
- Noise level according to EN 60704-3 and EN 60704-2-13 at maximum normal setting; extraction rate: 62 dB (A) re 1pW (48 dB (A) re 20 µPa sound pressure)
- Twin channel high performance fan motor
- Extractor hose 120mm
- 
- Dimensions recirculating with CleanAir module (HxWxD):  
689 x 600 x 500 mm - mounting with outer chimney  
809-1139 x 600 x 500 mm - mounting with telescopic chimney

## Serie | 2 Hoods

### Box style hood

### DWB064W50B Brushed steel

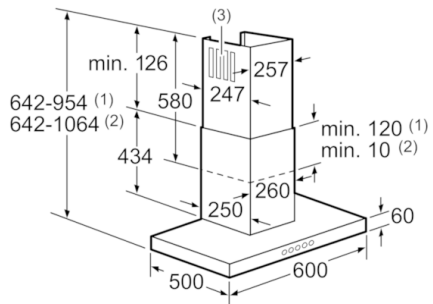

- (1) Exhaust air
- (2) Circulated air
- (3) Air outlet - install with vent at bottom for exhaust air

Measurements in mm