

Installation accessory DSZ4920



- Set for wall mounting
- Consisting of:
- 2 mounting brackets fixing material

Technical Data

Dimensions of the packed product (HxWxD): 190 x 260 x 350 mm
Pallet dimensions: 167.0 x 80.0 x 120.0
Standard number of units per pallet: 80
Net weight: 3.0 kg
Gross weight: 4.0 kg
EAN code: 4242002882475



Installation accessory

DSZ4920

Optional accessories

- Set for wall mounting
- Consisting of:
- 2 mounting brackets fixing material

Installation accessory DSZ4920

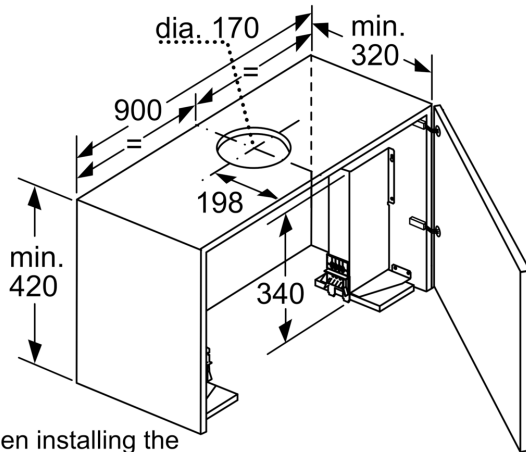

When installing the 90 cm telescopic hood in a 90 cm wide wall-hanging cupboard, the mounting kit is required. The two mounting brackets are screwed onto the right and left of the kitchen unit. Installation in accordance with template. measurements in mm