

Series 6, Integrated Design Hood, 60 cm, Clear glass black printed DBB67AM60B



B

- **Silent:** maximum extractor performance with little noise.
- **Expanded storage space:** the hood can hold up to 10 kg on each side. And even left and right beside the chimney shelves can be placed.
- **Glass panel with integrated TouchSelect control:** an automatic recognition of the glass panel position enables automatic operation of power level and light.
- **Easy to clean:** thanks to the well thought-out design, such as smooth surfaces, the hood is easy to clean.

Optional accessories

DWZ1IX1C6	Clean Air Plus recirc. kit external
DWZ6IB1B4	Clean Air Standard odor filter (repl.)
DWZ0ITOP0	Long Life odor filter (replacement)
DWZ1IB6K1	Chimney extension 450-854 mm
DWZ1IB6N1	Chimney extension 187-360 mm
DWZ1IT1D1	Long Life recirculation kit external
DWZ1IX1B6	Clean Air Plus odor filter (replacement)
DWZ6IB1I4	Clean Air Standard recirculation kit

Technical Data

Typology:	Built-in/Built-under
Length electrical supply cord:	130.0 cm
Min. required niche size for installation (HxWxD):	340mm x 560.0mm x 300mm mm
Minimum distance above an electric hob:	430 mm
Minimum distance above a gas hob:	650 mm
Net weight:	9.4 kg
Type of control:	Electronic
Number of speed settings:	3-stages + intensive setting
Max. air extraction:	460 m ³ /h
Boost position output recirculating:	652 m ³ /h
Max. air recirculation:	451 m ³ /h
Boost position air extraction:	749 m ³ /h
Maximum Air flow:	460 m ³ /h
Number of lights:	2
Noise level:	63 dB(A) re 1 pW
Diameter of air outlet:	120 / 150 mm
Grease filter material:	Washable stainless steel
EAN code:	4242005297948
Connection rating:	256 W
Voltage:	220-240 V
Frequency:	50 Hz
Plug type:	GB plug
Installation typology:	Built-in



Series 6, Integrated Design Hood, 60 cm, Clear glass black printed DBB67AM60B

Variant

- 60 cm wide
- For installation into a 60cm wide cupboard
- Suitable for ducted or recirculating operation
- For recirculated extraction various recirculation kits are available as optional accessories.

Design

- Flush-fitted installation for a seamless integration in wall cupboards.
- Space efficient compact design for extra storage possibilities on the hood, up to max. 10 kg storage weight per side.
- Glass panel with touch control for an easy operation and enhanced vapor capture.
- Extraction and lighting are automatically turned on and off by opening and closing the glass panel.
- Lighting can also be turned on and off when the glass panel is closed by quick hand touch on control panel.
- Includes mats for hood storage areas, protecting against scratches and to help prevent items moving in this space.

Features

- Electronic control via TouchControl
- 3 power levels & intensive setting
- Softlight dimmer function
- 2 x 2 W LED lights
- Colour Temperature: 3500 K
- Light Intensity: 451 lux
- Automatic intensive revert
- Automatic intensive revert (6mins)
- Steel filter cover
- 2 metal grease filter cassettes
- Easy to clean smooth surfaces and materials.

Performance

- Extraction rate according to EN 61591 ø 15 cm:
 - max. Normal use: 460 m³/h
 - Intensive: 749 m³/h
- Noise level according to EN 60704-3 and EN 60704-2-13 exhaust air:
 - Max. normal use: 63 dB(A) re 1 pW
 - Intensive: 73 dB(A) re 1 pW
 - Noise max. Normal Level: 63 dB*
- With the Clean Air Plus recirculation kit (available as optional accessory) your appliances reaches:
 - Extraction rate in recirculation mode: Max. normal use: 451 m³/h
 - Intensive: 652 m³/h
 - Noise level in recirculation mode: Max. normal use: 67 dB(A) re 1 pW
 - Intensive: 74 dB(A) re 1 pW

Planning and installation information

- Installation system: IDH comfort installation
- Suitable for installation in bottomless wall cupboards.
- Enclosed spacers for installation in wall cupboards with maximum depth of up to 360mm.
- For installation in higher wall cupboards chimney extensions are

available as optional accessories.

- Chimney extensions are compatible with the available recirculation kits.
- Dimensions (HxWxD): 340 x 597 x 298 mm
- Built-in dimensions (HxWxD): 340 x 560 x 300 mm
- Diameter pipe ø 150 mm (ø 120 mm enclosed)
- Back-pressure flap: Yes
- Electrical cable length 1.3 m
- Please reference the built-in dimensions provided in the installation drawing

Consumption Data

- Energy Efficiency Class: B (at a range of energy efficiency classes from A+++ to D)
- Average Energy Consumption: 62.7 kWh/year*
- Blower Efficiency Class: B*
- Lighting Efficiency Class: A*
- Grease Filtering Efficiency Class: B*
- Power rating: 256 W

* In accordance with the EU-Regulation No 65/2014

Series 6, Integrated Design Hood, 60 cm, Clear glass black printed DBB67AM60B

measurements in mm
Front view

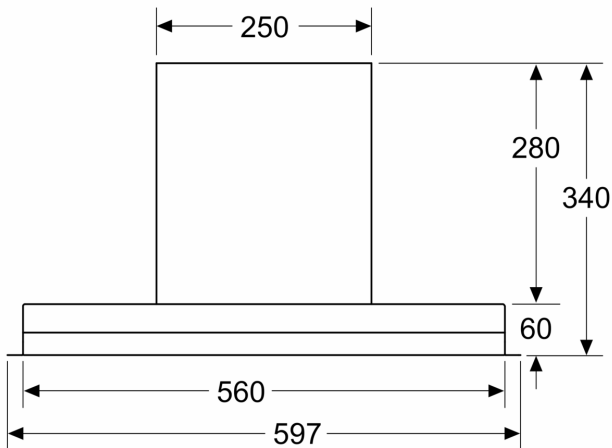

measurements in mm
Installation example

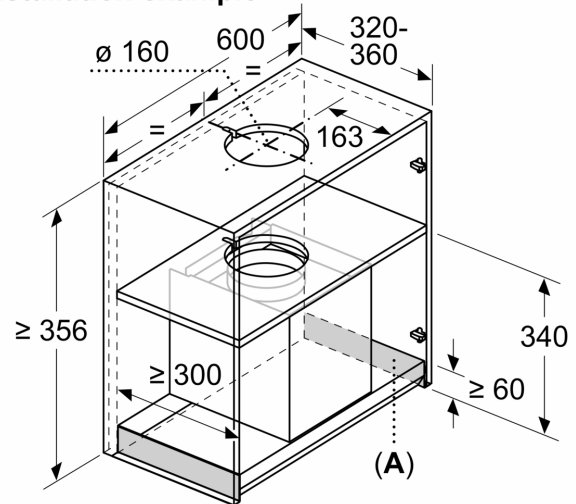

A: Area without hinges

measurements in mm

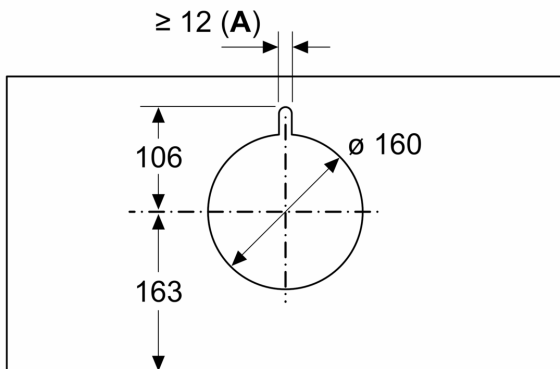

A: Cable bushing

measurements in mm

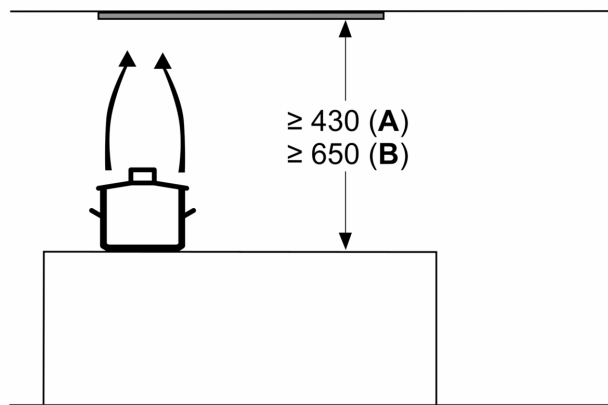

from upper edge of pan support
A: min. 430 electric
B: min. 650 gas

measurements in mm
side view

