

**IQ500, Built-in microwave, 59 x 38 cm, Black  
BF555LMB1B**



1 x Turntable	
HZ86D000	Steamer Cooker Accessory for Microwave
HZG9AS00S	Adapter

38 cm high built-in microwave for defrosting, reheating or preparation of dishes in the shortest possible time.

- ✓ Automatic programs ensure best results.
- ✓ The touchControl allows the temperature to be controlled by entering it directly or by moving the slider with a single finger.
- ✓ 900 Watts maximum: ideal for heating liquids
- ✓ The side-opening hinged door: ideal for elevated installation.

Additional functions:	Microwave only
Type of control:	Electronic
Dimensions:	382x594x388 mm
Cavity dimensions:	208 x 328 x 369 mm
Length electrical supply cord:	130.0 cm
Weight:	17.4 kg
Gross weight:	21.4 kg
EAN code:	4242003960295
Maximum micro-wave power:	900 W
Connection Rating:	1450 W
Fuse protection:	10 A
Nominal power:	220-230 V
Frequency:	50 Hz
Plug type:	GB plug
Included accessories:	1 x Turntable



## IQ500, Built-in microwave, 59 x 38 cm, Black BF555LMB1B

### Features

- Maximum microwave power level: 900 W and the following options: 180 W, 360 W, 600 W, 90 W, 900 W
- Cavity volume: 25 l

### Design

- Cavity inner surface: stainless steel

### Cleaning

#### Programmes/functions

- LED display, White display with blue indicator lights
- Electronic oven clock timer
- Touch control, touchSlider, Start button
- User-friendly electronics: extremely
- easy and comfortable operation
- cookControl, 7
- 4 defrost and 3 cooking programmes in microwave function
- 1 memory setting
- LED light
- 31.5 cm Glass turntable
- Left hinged door
- Electronic door opening button
- Touch key operation

#### Accessories

- 1 x Turntable

### Features

- Automatic safety switch off
- Door contact switch
- Integral cooling fan

### Technical information

- 130 cm Cable length
- Total connected load electric: 1.45 KW
- Nominal voltage: 220 - 230 V
- Installation in tall housing

### Performance/technical information

- Appliance dimension (hxwx): 382 mm x 594 mm x 388 mm
- Niche dimension (hxwx): 380 mm - 382 mm x 560 mm - 568 mm x 550 mm
- Please refer to the dimensions provided in the installation manual

**IQ500, Built-in microwave, 59 x 38 cm, Black  
BF555LMB1B**

Microwave,  
corner installation

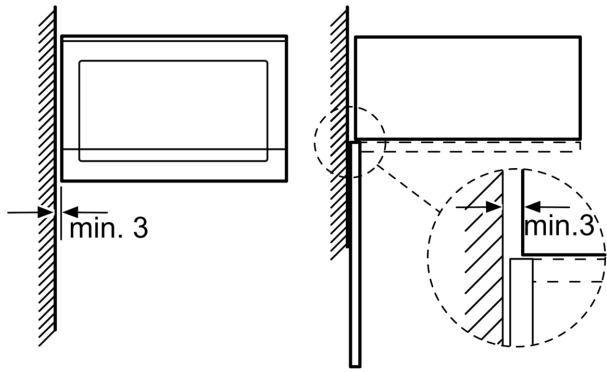

Measurements in mm

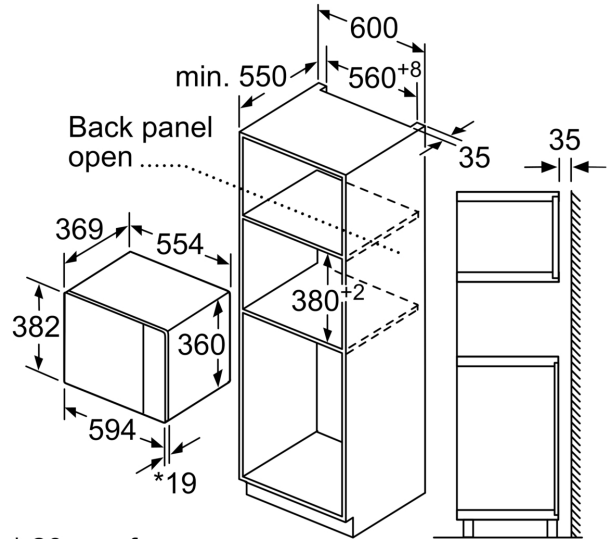

\* 20 mm for  
metal fascia

measurements in mm

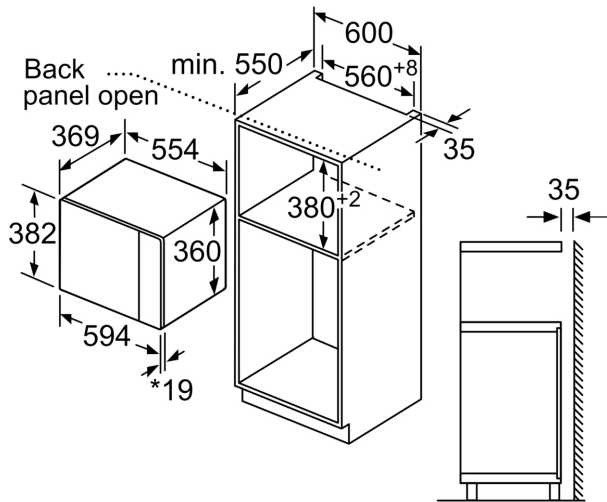

\* 20 mm for metal fascia

measurements in mm

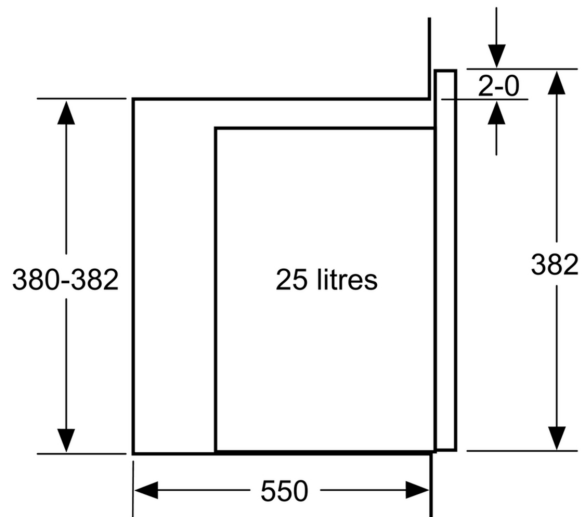

measurements in mm