

**Series 8, Heat pump tumble dryer, 9 kg
WQB246C9GB**



- WMZ20600 Wool in basket - accessory
- WTZ27500 Stacking kit with pull-out shelf
- WTZ27510 Stacking kit
- WTZPW20D Platform with pull-out, dryer, cubic

An exceptional heatpump dryer with Smart Dry powered by Home Connect. Maximise your energy savings with A+++ -10%* and the Self Cleaning condenser. Protect your Garments with Auto Dry and reduce your ironing Pile with Iron Assist.

- **A+++ rated:** Discover our highly efficient dryer
- **Self-Cleaning Condenser:** Automatic fluff-cleaning condenser.
- **Anti Vibration sidewall:** extremely stable and quiet thanks to special vibration protection.
- **Auto Dry:** Automatically senses when your load is dried.
- **Half Load option:** optimises the drying settings (load and duration) for small loads.

Built-in / Free-standing: Freestanding
 Removable top: No
 Door hinge: Right reversible
 Length electrical supply cord: 180.0 cm
 Dimensions: 842x598x613 mm
 Net weight: 55.2 kg
 Fluorinated greenhouse gases: No
 Hermetically sealed equipment: Yes
 EAN code: 4242005364428
 Connection rating: 600 W
 Fuse protection: 10 A
 Voltage: 220-240 V
 Frequency: 50 Hz
 Loading capacity: 9.0 kg
 Energy efficiency rating: A+++
 Energy consumption electric dryer, full load - NEW (2010/30/EC): 1.44 kWh
 Standard cotton programme time at full load: 260 min
 Energy consumption electric dryer, partial load - NEW (2010/30/EC): 0.80 kWh
 Standard cotton programme time at partial load: 156 min
 Weighted annual energy consumption, electric dryer - NEW (2010/30/EC): 174.0 kWh/annum
 Weighted programme time: 201 min
 Average condensation efficiency full load (%): 91 %
 Average condensation efficiency partial load (%): 91 %
 Weighted condensation efficiency (%): 91 %



Series 8, Heat pump tumble dryer, 9 kg WQB246C9GB

An exceptional heatpump dryer with Smart Dry powered by Home Connect. Maximise your energy savings with A+++ -10%* and the Self Cleaning condenser. Protect your Garments with Auto Dry and reduce your ironing Pile with Iron Assist.

- Appliance depth with open door: 110.5 cm
- Heat pump technology with climate friendly cooling agent

- ¹ At a range of energy efficiency classes from A+++ to D
- ³ Programme time of the standard cotton programme at full load
- ⁴ On a condensation efficiency class scale from A to G
- ⁵ Weighted condensation efficiency for the standard cotton programme at full and partial load

Performance

- Energy Efficiency Class¹: A+++
- 10% more efficient than energy efficiency class A+++**
- Energy²: 174 kWh
- Capacity: 1 - 9 kg
- Programme time³: 260 min
- Noise level: 58 dB (A) re 1 pW
- Condensation efficiency class⁴: A
- Condensation efficiency⁵: 91 %

Programmes/functions

- Standard programmes: cotton, easy care
- Special programmes: Cottons, Shirts/blouses, Cotton Eco, Delicates, Towels, Mixed Load, Sportswear, Easy-Care, Timed programme warm

Key features

- Half Load option: optimises drying for smaller loads
- Anti crease cycle 120 min at the end of the programme
- Touch control buttons: Iron dry, Cupboard dry, Cupboard dry+, end Time Delay, Reduced ironing, My favorite, Power button, Remote Start, Low heat, Start / Reload / Pause, speedPerfect, 24 h end Time Delay

Additional features

- SC1R
- Load recommendation
- Fully electronic control dial for sensor programmes and timed programmes
- Sensitive drying: large stainless steel drum with textile care and revolution drying system
- AntiVibration design: for greater stability and quietness
- No
- Drum interior light
- Container for condensed water
- Child lock
- Buzzer to indicate the end of cycle
- Usage meter: counts completed programmes
- Door hinge: right-hand, reversible
- Metal door catch

Technical Information

- slide-under installation
- Dimensions (H x W): 84.2 cm x 59.8 cm
- Appliance depth: 61.3 cm
- Appliance depth incl. door: 65.1 cm

**Series 8, Heat pump tumble dryer, 9
kg
WQB246C9GB**

Measurements in mm

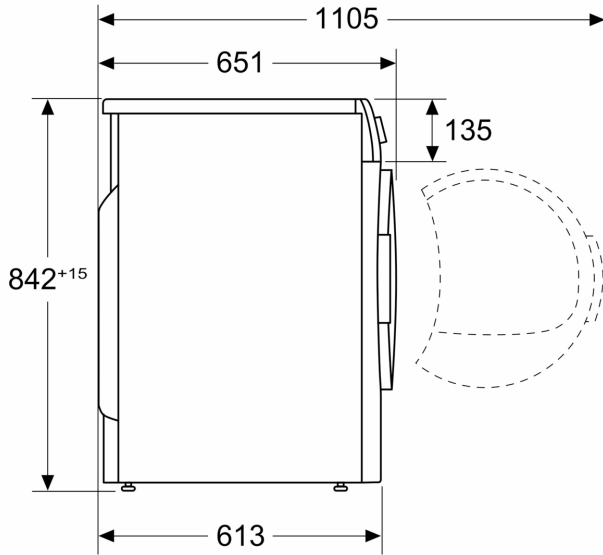

Measurements in mm

