

## iQ700, Heat pump tumble dryer, 9 kg WQ46B2C9GB



**A+++**



WZ20600	Wool in basket - accessory
WZ27500	Stacking kit with pull-out shelf
WZ27510	Stacking kit
WZDP20D	Platform with pull-out, dryer, cubic

The intelligent dryer for fast and gentle drying with resource saving A+++ -10%\*, varioSpeed, smartFinish and intelligentDry powered by Home Connect.

- ✓ autoDry – gentle and precise drying that protects your clothes.
- ✓ selfCleaning condenser: removes fluff to save you time and effort.
- ✓ intelligentDry: automatically adapts the drying cycle to match the washing programme.
- ✓ smartFinish – smooth away creases to cut down on ironing.
- ✓ Reversible drum – prevents large laundry pieces from tangling by alternating the drum rotation.

Built-in / Free-standing: .....	Freestanding
Removable top: .....	No
Door opening: .....	Right reversible
Length electrical supply cord: .....	180.0 cm
Dimensions: .....	842 x 598 x 613 mm
Weight: .....	56.5 kg
Fluorinated greenhouse gases: .....	No
Type of refrigerant: .....	R290
Hermetically sealed equipment: .....	Yes
EAN code: .....	4242003927540
Connection Rating: .....	600 W
Fuse protection: .....	10 A
Nominal power: .....	220-240 V
Frequency: .....	50 Hz
Capacity: .....	9.0 kg
Energy efficiency rating: .....	A+++
Energy consumption electric dryer, full load - NEW (2010/30/EC):	1.44 kWh
Standard cotton programme time at full load: .....	260 min
Energy consumption electric dryer, partial load - NEW (2010/30/EC):	0.80 kWh
Standard cotton programme time at partial load: .....	156 min
Weighted annual energy consumption, electric dryer - NEW (2010/30/EC): .....	174.0 kWh/annum
Weighted programme time: .....	201 min
Average condensation efficiency full load (%): .....	91 %
Average condensation efficiency partial load (%): .....	91 %
Weighted condensation efficiency (%): .....	91 %



## iQ700, Heat pump tumble dryer, 9 kg WQ46B2C9GB

### Performance

- Energy Efficiency Class<sup>1</sup>: A+++
- 10% more efficient than energy efficiency class A+++\*\*\*
- Energy<sup>2</sup>: 174 kWh
- Capacity: 1 - 9 kg
- Programme time<sup>3</sup>: 260 min
- Noise level: 58 dB (A) re 1 pW
- Condensation efficiency class<sup>4</sup>: A
- Condensation efficiency<sup>5</sup>: 91 %

### Programmes/functions

- Standard programmes: cotton, easy care
- Special programmes: cotton, shirts, Cotton Eco, towels, mixed fabrics, outdoor, rapid 40, easy-care, wool drying in basket, timed programme warm

### Key features

- Half Load option: optimises drying for smaller loads
- Anti crease cycle 120 min at the end of the programme
- Touch control buttons: Iron dry, Cupboard dry, Cupboard dry+, end time delay, less ironing, myFavorite, Power button, remote start, low heat, Start / Reload / Pause, speedPerfect, 24 h end time delay

### Additional features

- SC1R
- Load recommendation
- Fully electronic control dial for sensor and timed programmes
- Jog dial with integrated on/off control
- Sensitive drying: large softDry stainless steel drum system and revolution drying system
- AntiVibration design: for greater stability and quietness
- Wool drying basket
- Drum interior light
- Container for condensed water
- Child lock
- End of cycle buzzer
- Usage meter: counts completed programmes
- Door hinge: right-hand, reversible
- Metal door catch
- Slide-under installation
- Dimensions (H x W): 84.2 cm x 59.8 cm
- Appliance depth: 61.3 cm
- Appliance depth incl. door: 66.5 cm
- Appliance depth with open door: 110.5 cm
- Heat pump technology with climate friendly cooling agent

<sup>1</sup> At a range of energy efficiency classes from A+++ to D

<sup>2</sup> Energy consumption kWh per year, based on 160 drying cycles of the standard cotton programme at full and partial load, and the consumption of the low power modes

<sup>3</sup> Programme time of the standard cotton programme at full load

<sup>4</sup> On a condensation efficiency class scale from A to G

\*\*\* 10% more efficient (174 kWh/year) than the limit value (194kWh/year) of the energy efficiency class A+++ in category 9kg according to delegated EU-Regulation 392/2012

**iQ700, Heat pump tumble dryer, 9  
kg  
WQ46B2C9GB**

Measurements in mm

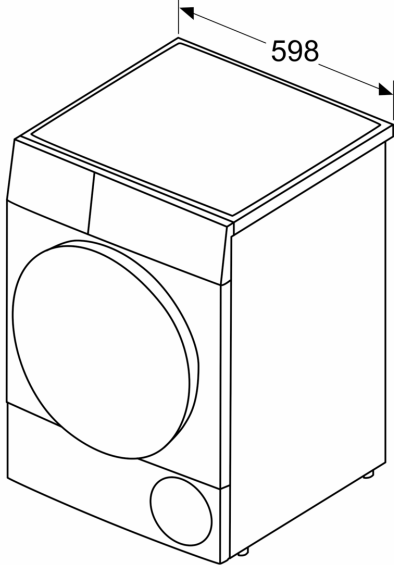

Measurements in mm

