

**iQ700, Washing machine, front loader, 10 kg, 1400 rpm
WM14XEH5GB**



Wifi-enabled washing machine with Home Connect: Enjoy the intelligent automatic dosing system and save time with the integrated speedPack.

- ✓ i-Dos – Automatically doses the precise amount of detergent and water.
- ✓ speedPack XL: speed up your wash or use one of the fixed preset speed programmes.
- ✓ Home Connect app (Android and iOS): access and control your washing machine, wherever you are.
- ✓ Remote control: manage your wash with your mobile device.
- ✓ Push notifications: know what your machine needs with the Home Connect app.

Energy Efficiency Class: B
 Weighted energy consumption in kWh per 100 washing cycles of eco 40-60 programme: 56 kWh
 Maximum capacity in kg: 10.0 kg
 The water consumption of the eco programme in liters per cycle: 49 l
 Duration of eco 40-60 programme in hours and mins at rated capacity: 3:58 h
 Spin-drying efficiency class of eco 40-60 programme: B
 Airborne acoustical noise emission class: A
 Airborne acoustical noise emissions : 71 dB(A) re 1 pW
 Built-in / Free-standing: Freestanding
 Dimensions of the product: 848 x 598 x 590 mm
 Weight: 83.6 kg
 Connection Rating: 2300 W
 Fuse protection: 10 A
 Nominal power: 220-240 V
 Frequency: 50-60 Hz
 Length electrical supply cord: 210.0 cm
 Door opening: Left
 Wheels: No
 EAN code: 4242003896136
 Installation type: Freestanding



WX975600	Floor securing component
WZ10131	Extension for cold water inlet /Aquastop
WZWP20W	Platform with pull-out, washer, cubic

iQ700, Washing machine, front loader, 10 kg, 1400 rpm WM14XEH5GB

Performance

- Energy Efficiency Class¹: B
- Energy² / Water³: 56 kWh / 49 litres
- Load capacity: 1 - 10 kg
- Programme duration⁴: 3:58 h:min
- Spin drying efficiency class: B
- Spin speed^{**}: 400 - 1400 rpm
- Noise level: 71 dB (A) re 1 pW
- Noise efficiency class: A

Programmes/functions

- Standard programmes: cottons, easy care, delicates, wool hand wash
- Series / project: W_F55C-Xi
- Special programmes: drain, automatic soft, automatic, drum clean with reminder, shirts/blouses, jeans/dark laundry, Outdoor, PowerWash 59, Spin, mixed fabrics, single rinse, duvet, rapid 15 minute quick wash

Key features

- Home Connect: Remote Monitoring and Control, Remote diagnostics, Energy management
- i-Dos: automatic dosing of liquid detergent and softener
- autoStain removal system (ASR) with 16 stain options
- Options: extra rinse cycles, less ironing, Soaking, auto stain (16 options), i-DOS 2.0 1, i-DOS 2.0 2, night wash, speedPerfect, Rinse hold, prewash, waterPlus
- Touch control buttons: basic settings, On/off, Ready in, stain selection, i-DOS 2.0, options, remote start, start/pause with reload function, temperature selection, varioSpeed, spin speed selection/Rinse Hold

Additional features

- Reload Function: Stop the washing machine to add any forgotten items of laundry to the drum.
- TFT display: Clear text and high resolution for easy use with display of programme indication, temperature selection, spin speed, remaining time, 24 hour time delay and consumption indication
- powerSpeed system: better washing results in less time
- Drum volume: 70 litres
- drum interior light
- waveDrum: for highly effective and extremely gentle laundry care
- drum clean with reminder function
- Large chrome-black door with 180° opening
- Reload function: Pause the already running washing machine to add any forgotten items of laundry to the drum.
- iQdrive with 10 year warranty
- iQdrive with 10 year warranty
- waterPerfect Plus: for efficient use of water even with small loads thanks to intelligent sensor technology.
- Consump indicator energy+water, autoLoad Plus, autoStain removal system (ASR)
- antiVibration Design - for more stability and quietness

- Sound insulation by additional noise reduction material
- hydroSensor monitors and controls rinse cycles
- aquaStop: Siemens home appliance with lifetime warranty against water damage*
- Consumption indicator: Information about water and energy consumption prior to start of programme
- Jog dial with integrated on/off control
- Foam detection system
- Detergent over dosage display
- Out of balance load adjustment
- Electronic child safety package
- Acoustic signals: Multi-tone

Technical Information

- Slide-under installation
- Dimensions (H x W): 84.8 cm x 59.8 cm
- Appliance depth: 59.0 cm
- Appliance depth incl. door: 63.2 cm
- Appliance depth with open door: 108.5 cm

¹ Scale of Energy Efficiency Classes from A to G

² Energy consumption in kWh per 100 cycles (in programme Eco 40-60)

³ Weighted water consumption in litres per cycle (in programme Eco 40-60)

⁴ Duration of Eco 40-60 programme

** Values are rounded.

* Please find warranty terms under the additional warranties section of our website.

**iQ700, Washing machine, front loader, 10 kg, 1400 rpm
WM14XEH5GB**

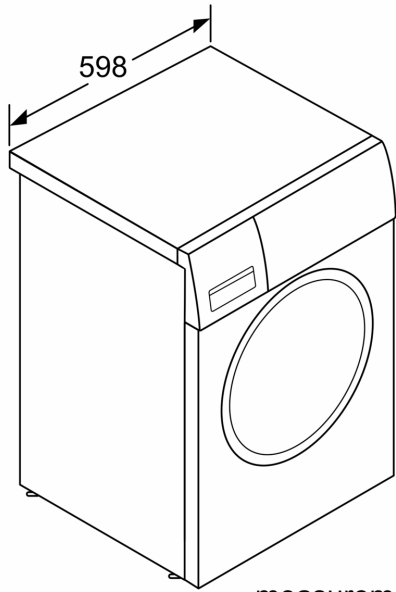

measurements in mm

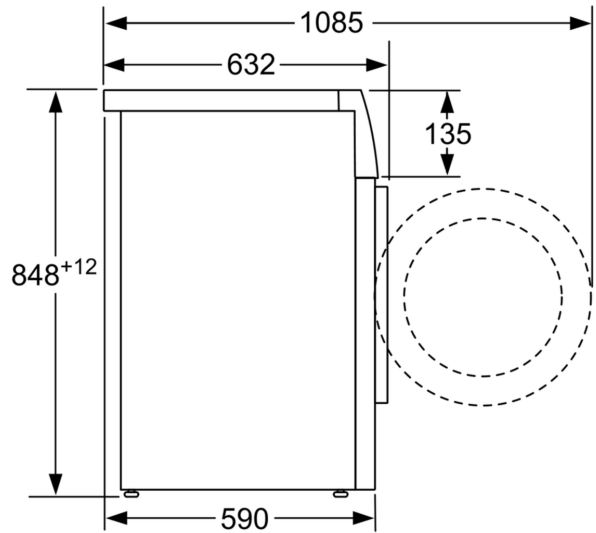

measurements in mm