

**Series 8, Washing machine, front loader, 10 kg, 1400 rpm
WGB256A1GB**

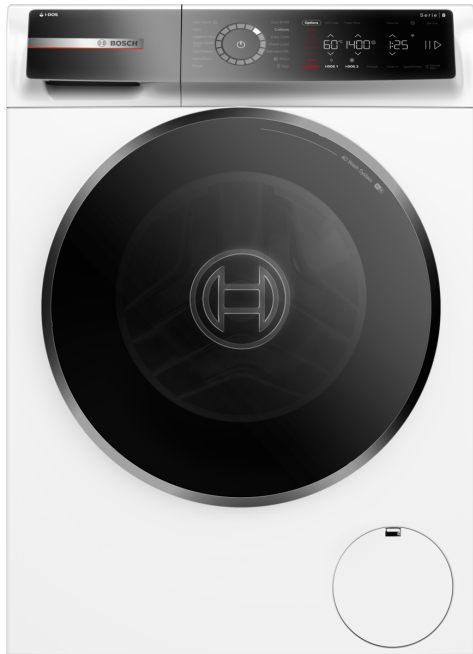

An exceptional washing machine with i-Dos and detergent scan powered by Home Connect which saves water and detergent. Maximise your energy savings with A-20%* and reduce your ironing pile with Iron Assist.

- **A rated:** save energy with our most efficient A rated appliances
- **Speed Perfect:** Cuts the cycle time by up to 65%* without compromising on results.
- **Super Quick 30:** Faster washing when you need it.
- **Iron Assist:** Reduces wrinkles and your ironing pile
- **Anti Stain:** Tackles four stubborn types of stain with ease.

Energy Efficiency Class: A
 Weighted energy consumption in kWh per 100 washing cycles of eco 40-60 programme: 41 kWh
 Maximum capacity in kg: 10.0 kg
 The water consumption of the eco programme in liters per cycle: 49 l
 Duration of eco 40-60 programme in hours and mins at rated capacity: 3:50 h
 Spin-drying efficiency class of eco 40-60 programme: B
 Airborne acoustical noise emission class: A
 Airborne acoustical noise emissions : 70 dB(A) re 1pW
 Built-in / Free-standing: Freestanding
 Dimensions of the product: 845x598x590 mm
 Net weight: 82.8 kg
 Connection rating: 2300 W
 Fuse protection: 10 A
 Voltage: 220-240 V
 Frequency: 50-60 Hz
 Length electrical supply cord: 210.0 cm
 Door hinge: Left
 Wheels: No
 EAN code: 4242005396214
 Installation typology: Free-standing

- WMZ2200 Floor securing component
 WMZ2381 Extension for cold water inlet /Aquastop
 WMZPW20W Platform with pull-out, washer, cubic



Series 8, Washing machine, front loader, 10 kg, 1400 rpm WGB256A1GB

An exceptional washing machine with i-Dos and detergent scan powered by Home Connect which saves water and detergent. Maximise your energy savings with A-20%* and reduce your ironing pile with Iron Assist.

Performance

- Energy Efficiency Class¹: A
- A -20%: 20% more efficient than the limit value of Energy Efficiency Class A****
- Energy² / Water³: 41 kWh / 49 litres
- Load capacity: 1 - 10 kg
- Programme duration⁴: 3:50 h:min
- Spin drying efficiency class: B
- Spin speed^{**}: 400 - 1400 rpm
- Noise level: 70 dB (A) re 1 pW
- Noise efficiency class: A

Programmes/functions

- Standard programmes: cottons, easy care, delicates, wool hand wash
- Series / project: W_F55C-PG1.5CU-i
- Iron Assist: Steam programme that reduces wrinkles on dry clothes
- Special programmes: Automatic, Drain / Spin, Mixed Load, Sportswear, Single Rinse, Super Quick 15/30, Hygiene

Key features

- Home Connect: Remote Monitoring and Control, Energy Management, Remote Diagnostics, further programmes via download. Always keep your appliance up to date via firmware update.
- i-DOS: automatic dosing of liquid detergent and softener
- Automatic stain removal - 6 stains at the touch of a button, 10 further stains via Home Connect
- Touch control buttons: On/off, Ready in, stain selection, i-DOS 1, i-DOS 2, child lock, Memory, Power rinse, Remote Start, start/pause with reload function, Temperature selection, SpeedPerfect, Prewash, Spin speed reduction/Rinse Hold

Additional features

- Reload function: Flexibility to add or remove laundry items of any size even after start of the wash cycle.
- Elegant and ergonomically inclined control panel for easy use
- 4D Wash System: highly efficient water and detergent fabric penetration for spotless results.
- Hygiene Plus: clean laundry and effective removal of germs
- Mini Load: Wash single items and small loads efficiently
- Drum volume: 70 litres
- Drum interior light
- VarioDrum: gentle and efficient washing
- Large black-chrome, black door with 182° opening
- Reload function: Flexibility in adding laundry items into the drum, even after the wash cycle has started.

- EcoSilence drive with 10 year warranty
- AntiVibration Design - for more stability and quietness
- ActiveWater Plus: for highly efficient use of water even with smaller loads thanks to automatic load detection.
- Sound insulation by additional noise reduction material
- Turbidity sensor
- AquaStop: Bosch home appliance with lifetime warranty against water damage*
- Foam detection system
- Overdosage indication
- Safeguard monitoring system adjusts load distribution and programme settings to protect clothes
- Child lock
- Acoustic signals: Buzzer
- Detergent dispensing: i-DOS 2.0
- Usage meter: counts completed programmes

Technical Information

- Slide-under installation
- Dimensions (H x W): 84.5 cm x 59.8 cm
- Appliance depth: 59.0 cm
- Appliance depth incl. door: 64.8 cm
- Appliance depth with open door: 109.0 cm

¹ Scale of Energy Efficiency Classes from A to G

² Energy consumption in kWh per 100 cycles (in programme Eco 40-60)

³ Weighted water consumption in litres per cycle (in programme Eco 40-60)

⁴ Duration of Eco 40-60 programme

** Values are rounded.

**** 20% more efficient (41 kWh/100 cycles) than the limit value (51,4 kWh / 100 cycles) of the energy efficiency class A according to delegated EU-Regulation 2019/2014.

* Please find warranty terms under the additional warranties section of our website.

**Series 8, Washing machine, front
loader, 10 kg, 1400 rpm
WGB256A1GB**

Measurements in mm

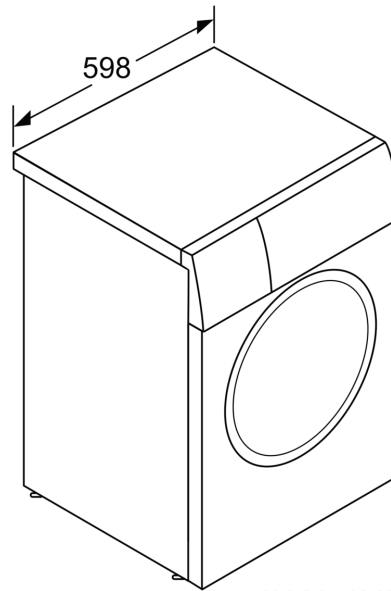

measurements in mm