

**Series 2, Fully-integrated  
dishwasher, 60 cm  
SMV2ITX18G**



- SGZ0BI02 decorative strips stainless steel 81,5cm
- SGZ1010 inlet and outlet hose extension
- SGZ8BI00 Connection rail for divided furniture
- SMZ2056 Attachment door, stainless steel
- SMZ5003 Retractable hinge f. high corpus dimens.
- SMZ5300 GlassSecure Tray

**Connected dishwasher with noise  
reduction at any time via the Home  
Connect App.**

- **ExtraDry:** extra drying option for difficult-to-dry loads.
- **SpeedPerfect:** Reduced washing time, perfectly cleaned dishes.
- **Silence on demand:** up to 30 min noise reduction at any time via the Home Connect App.
- **Home Connect:** an easy solution to help you get the most out of your appliance, with flexible control and additional features.
- **EcoSilence Drive:** especially energy-saving and silent in operation with a particularly high life span.

Energy Efficiency Class: ..... E  
 Energy Consumption for 100 cycles Eco Programme: ..... 92 kWh  
 Maximum number of place settings: ..... 12  
 The water consumption of the eco programme in liters per cycle: 10.5 l  
 Programme duration: ..... 4:30 h  
 Airborne acoustical noise emissions : ..... 48 dB(A) re 1pW  
 Airborne acoustical noise emission class: ..... C  
 Built-in / Free-standing: ..... Built-in  
 Height of removable worktop: ..... 0 mm  
 Dimensions of the product (HxWxD): ..... 815 x 598 x 550 mm  
 Min. required niche size for installation (HxWxD): ..... 815-875 x 600 x 550 mm  
 Depth with open door 90 degree: ..... 1150 mm  
 Adjustable feet: ..... Yes - all from front  
 Maximum adjustability feet: ..... 60 mm  
 Adjustable plinth: ..... Both horizontal and vertical  
 Net weight: ..... 31.1 kg  
 Gross weight: ..... 33.2 kg  
 Connection rating: ..... 2400 W  
 Fuse protection: ..... 10 A  
 Voltage: ..... 220-240 V  
 Frequency: ..... 50; 60 Hz  
 Length electrical supply cord: ..... 175.0 cm  
 Plug type: ..... GB plug  
 Length inlet hose: ..... 165 cm  
 Length outlet hose: ..... 190 cm  
 EAN code: ..... 4242005275069  
 Installation typology: ..... Integrated



## Series 2, Fully-integrated dishwasher, 60 cm SMV2ITX18G

### Connected dishwasher with noise reduction at any time via the Home Connect App.

---

#### Performance

- Energy Efficiency Class<sup>1</sup>: E
- Energy<sup>2</sup> / Water<sup>3</sup>: 92 kWh / 10.5 litres
- Capacity: 12 place settings
- Programme duration<sup>4</sup>: 4:30 (h:min)
- Noise level: 48 dB(A) re 1 pW
- Noise Efficiency Class: C

#### Programmes / functions

- 5 programmes: Eco 50 °C, Auto 45-65 °C, Intensive 70 °C, Express 65°, Favourite
- Default favourite programme: Pre-Rinse
- 4 special options: Remote Start, Extra Dry, Half Load, SpeedPerfect
- Machine Care
- Silence on Demand (via app)

#### Flexible design elements

- Normal baskets
- Low friction wheels on bottom basket
- Rack Stopper to prevent derailing of bottom basket
- Cutlery basket in lower rack
- Upper rack cup shelf
- Glass holder in top basket

#### Innovations and technology

- Home Connect ready on WLAN
- DosageAssist detergent dispenser
- EcoSilence BLDC drive
- Automatic detergent detection
- AquaSensor III
- AquaMix - Glass protection system

#### Design features

- Push button top edge controls
- InfoLight (Red) - Light projection on the floor
- Time delay (3, 6 or 9 hours)
- AquaStop: Bosch's warranty in case of water damage - for the lifetime of the appliance. Please find warranty terms under <https://www.bosch-home.co.uk/customer-service/care-protection-and-parts/additional-warranties>
- Self cleaning filter system with 3 piece corrugated filter
- Large item spray head, incl. Steam protection for worktop
- Stainless steel/Polinox interior
- Dimensions (HxWxD): 81.5 x 59.8 x 55cm

<sup>1</sup> Scale of Energy Efficiency Classes from A to G

<sup>2</sup> Energy consumption in kWh per 100 cycles (in programme Eco 50 °C)

<sup>3</sup> Water consumption in litres per cycle (in programme Eco 50 °C)

**Series 2, Fully-integrated  
dishwasher, 60 cm  
SMV2ITX18G**

measurements in mm

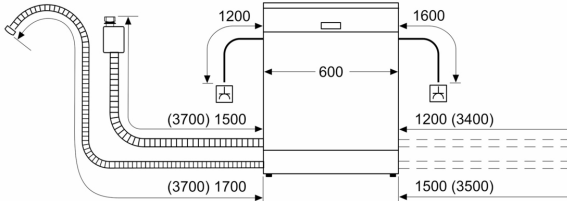

socket  
( ) values with extension kit

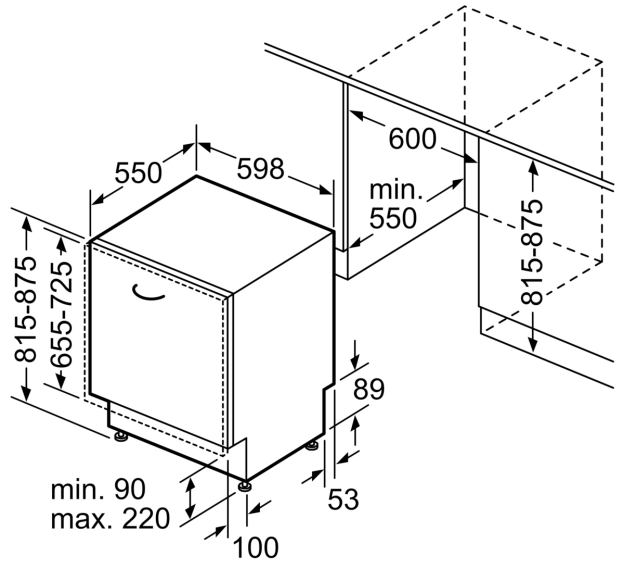

measurements in mm