

iQ100, Wall-mounted cooker hood, 80 cm, clear glass black printed, Black LC85KDK60B



Optional accessories	
LZ11GKU13	Standard recirculation kit

The Inclined Hood with touchControl and a low-noise motor for an odor-and noise-free kitchen.

- ✓ Intensive setting revert - increased power when steam escapes, and an automatic revert after a few minutes.
- ✓ Quiet and powerful extraction for a peaceful kitchen.
- ✓ Illuminate your cooking space with LED lights for optimal visibility and ambience setting.
- ✓ touchControl: quickly and easily manage the power levels and the LED light
- ✓ Filter saturation - Automatic reminders to clean and replace the filters ensure performance.

Features

Technical Data

Color chimney:	Black
Typology:	Wall-mounted
Length electrical supply cord:	150 cm
Height of the appliance:	325 mm
Minimum distance above an electric hob:	450 mm
Minimum distance above a gas hob:	650 mm
Weight:	11.5 kg
Control panel:	Electronic
Number of speed settings:	3-stages + intensive setting
Maximum output air extraction:	430 m ³ /h
Boost position output recirculating:	550.0 m ³ /h
Maximum output recirculating air:	445 m ³ /h
Boost position air extraction:	550 m ³ /h
Maximum Air flow:	430 m ³ /h
Number of lights:	2
Noise level:	60 dB(A) re 1pW
Diameter of air outlet:	150 mm
Grease filter material:	Washable aluminium
EAN code:	4242003977163
Connection Rating:	223 W
Fuse protection:	4 A
Nominal power:	220-240 V
Frequency:	50 Hz
Plug type:	GB plug
Installation type:	Wall-mounted



iQ100, Wall-mounted cooker hood, 80 cm, clear glass black printed, Black LC85KDK60B

Features

Design:

- Inclined glass common design
- wall-mounted
- Black glass
- Suitable for ducted and re-circulating operation
- For recirculated extraction recirculating kit (accessory) needed

Core Features:

- Capacitor motor
- 2 x LED lights
- Colour Temperature: 4000 K
- Light Intensity: 127 lux
- 1 metal grease filter(s).

Comfort Features:

- Electronic control via touchControl, backlighted
- 3 x power levels plus intensive setting
- Automatic reset from intensive to normal setting after 5 min
- Grease and charcoal filter saturation indicators

Cleaning Comfort:

- Large opening angle of the glass plate with locking function for an easy filter accessibility and easy cleaning.
- Easy to clean smooth surfaces and materials.
- Steel filter cover dishwasher-safe

Performance Exhaust:

- According to EN 61591 and EN/ IEC 60704-2-13 your appliance can achieve the following values in exhaust mode: Speed 1: extraction rate 220 m³/h; noise level 46 dB (A) re1pW Speed 2: extraction rate 315 m³/h; noise level 53 dB (A) re1pW Speed 3: extraction rate 430 m³/h; noise level 60 dB (A) re1pW Intensive 1: extraction rate 550 m³/h; noise level 65 dB (A) re1pW
- Energy Efficiency Class: A (at a range of energy efficiency classes from A+++ to D)
- Average Energy Consumption: 43.8 kWh/year*
- Blower Efficiency Class: A*
- Lighting Efficiency Class: A*
- Grease Filtering Efficiency Class: E*

Performance Recirculation:

- According to EN 61591 and EN/ IEC 60704-2-13 your appliance can achieve the following values in recirculation mode with standard recirculation kit (available as optional accessory): Speed 1: extraction rate 215 m³/h; noise level 51 dB (A) re1pW Speed 2: extraction rate 300 m³/h; noise level 61 dB (A) re1pW Speed 3: extraction rate 445 m³/h ; noise level 69 dB (A) re1pW Intensive Speed 1: extraction rate 550 m³/h; noise level 72 dB (A) re1pW)

Technical Information and Sustainability:

- Consumption data:
- Power rating: 223 W
- Voltage: Nominal voltage: 220 - 240 V

Planning and Installation Information:

- Dimensions exhaust air (HxWxD): 690-900 x 790 x 325 mm
- Dimensions recirculating (HxWxD): 720-975 x 790 x 325 mm
- Diameter pipe Ø 150 mm
- Electrical cable length 1.5 m
- Back-pressure flap: Yes

iQ100, Wall-mounted cooker hood, 80 cm, clear glass black printed, Black
LC85KDK60B

Dimensioned drawings

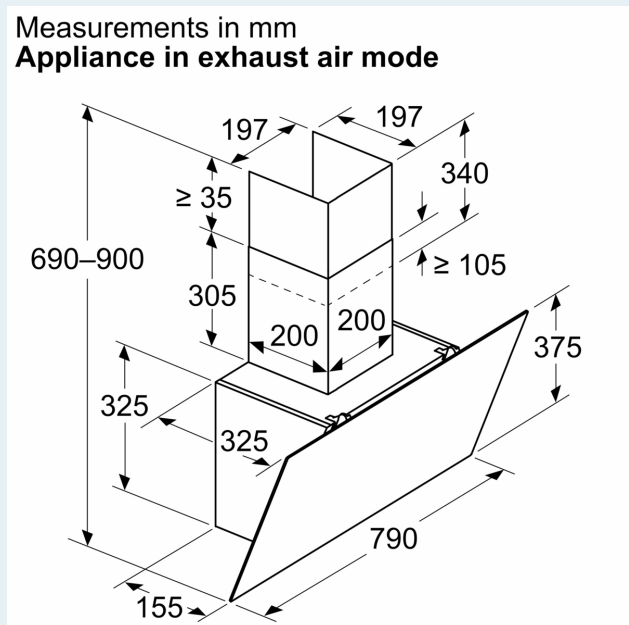
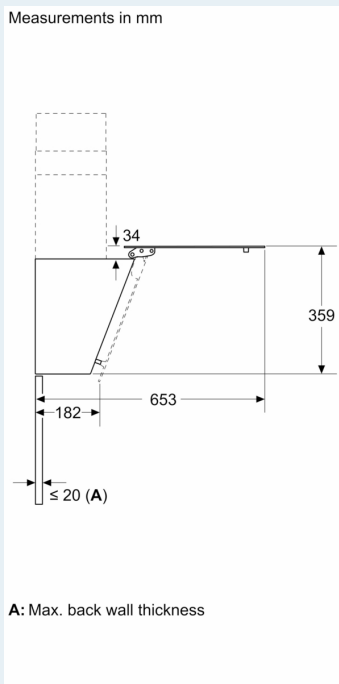
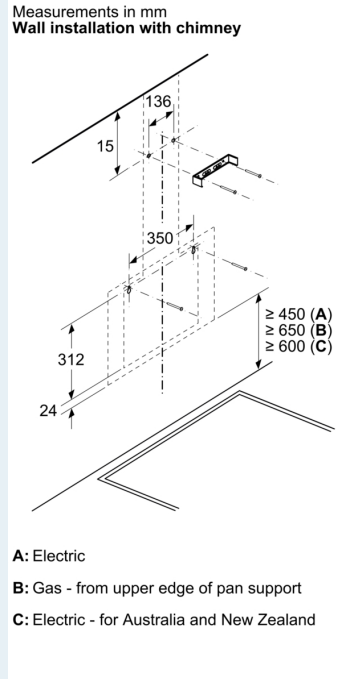
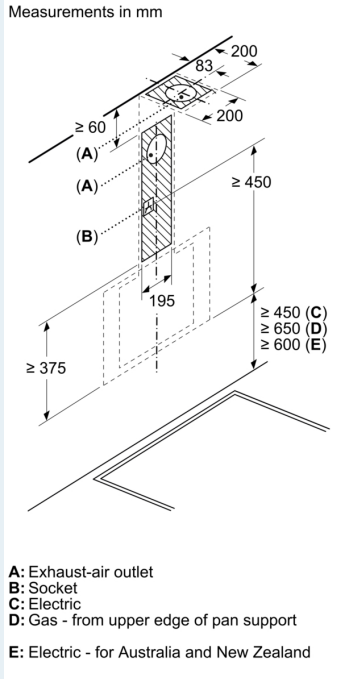

Dimensioned drawings

Measurements in mm
Appliance in circulated air mode

