

**Series 2, Built-in fridge-freezer with freezer at bottom, 177.2 x 54.1 cm, flat hinge  
KIN86NFE0G**



KSZB6R00 Bottle Rack  
KSZGGM00 Butter box

**The spacious built-in fridge-freezer combination with NoFrost provides optimal food storage and ice formation is no longer an issue.**

- **MultiBox XXL:** extra-large drawer for your fruit and vegetables.
- **No Frost:** never defrost again, thanks to perfect protection from ice formation - that saves time and effort.
- **Eco Airflow:** maintains optimal air circulation and a constant temperature level throughout the cooling area.
- **LED lighting:** all your items in perfect view.
- **Safety Glass Shelves:** safely store food in your fridge with stable, shatterproof glass shelves.

Energy Efficiency Class: .....	E
Average annual energy consumption in kilowatt hour per year (kWh/a): .....	234 kWh/annum
Sum of volume of frozen compartments: .....	76 l
Sum of volume of chill compartments: .....	184 l
Airborne acoustical noise emissions : .....	35 dB(A) re 1pW
Airborne acoustical noise emission class: .....	B
Built-in / Free-standing: .....	Built-in
Door panel options: .....	Not possible
Height: .....	1772 mm
Width of the appliance: .....	541 mm
Depth: .....	548 mm
Min. required niche size for installation (HxWxD):	1775.0 x 560 x 550 mm
Net weight: .....	52.6 kg
Fuse protection: .....	10 A
Door hinge: .....	Right reversible
Voltage: .....	220-240 V
Frequency: .....	50 Hz
Length electrical supply cord: .....	230.0 cm
Number of compressors: .....	1
Number of independent cooling systems: .....	1
Interior ventilator: .....	No
Reversible Door Hinge: .....	Yes
Number of Adjustable Shelves in fridge compartment: .....	3
Shelves for Bottles: .....	No
Frost free system: .....	Freezer
Installation typology: .....	Integrated



## Series 2, Built-in fridge-freezer with freezer at bottom, 177.2 x 54.1 cm, flat hinge KIN86NFE0G

Additional features  
Design features  
Dimension and installation

**The spacious built-in fridge-freezer combination with NoFrost provides optimal food storage and ice formation is no longer an issue.**

### Performance and Consumption

- EU19\_EEK\_D: E
- Total Volume : 260 l
- Annual Energy Consumption: 234 kWh/a
- EU19\_Fast freezer facility\_D
- Noise Level : 35 dB , EU19\_Noise emission class\_D: B

### Functions

- Bright interior LED fridge light in fridge section

### Design features

- LED electronic control
- Super Cooling: automatic deactivation
- Automatic defrost fridge
- Optical and accoustical

### Design features

- Net Fridge Volume : 184 l
- 4 safety glass shelves of which 3 are height adjustable
- Door shelves in fridge door: 1 large and 2 small.

### Freshness System

- 1 MultiBox - Transparent drawer with a rippled bottom, ideal for storing fruits and vegetables.

### Food freshness system

- Net Freezer Volume : 76 l
- Freezing capacity 24h : 4 kg
- Temperature rise time : EU19\_Temperature rise time\_D: 10 H
- NO\_FROST\_NEU\_BL, never have to defrost ever again
- SuperFreeze function with automatic deactivation
- 3 freezer drawers

### Dimension and installation

- Dimensions: 177.2 cm H x 54.1 cm W x 54.8 cm D
- Niche Dimensions: 177.5 cm H x 56 cm W x 55 cm D

### Key features - Fridge section

- Right hinged door, door reversible
- 220 - 240 V
- Length of power cord:230 cm
- Height adjustable front feet
- Climate Class: SN-ST

### Country Specific Options

- Based on the results of the standard 24-hour test. Actual consumption depends on usage/position of the appliance.

### Key features - Freezer section

- 3 x egg tray, 1 x ice cube tray

**Series 2, Built-in fridge-freezer with freezer at bottom, 177.2 x 54.1 cm, flat hinge  
KIN86NFE0G**

measurements in mm

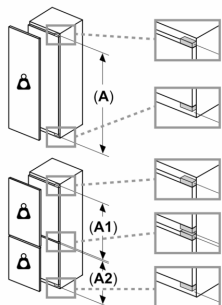
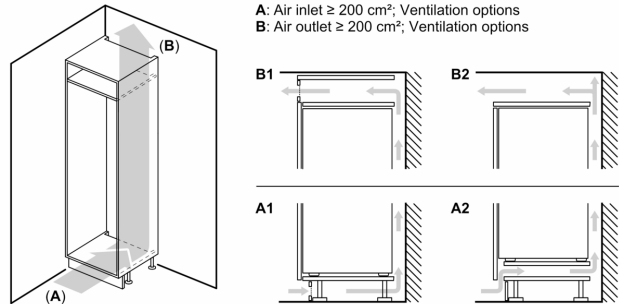
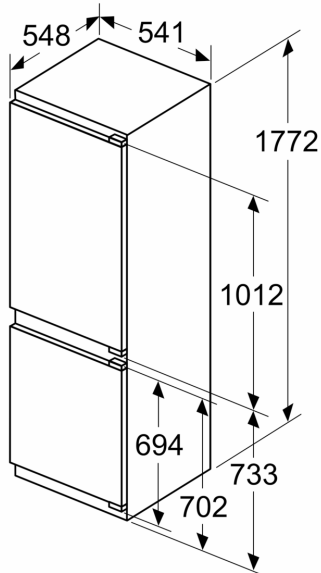

**Maximal permissible weight of the unit fronts**

Fitted unit fronts that exceed the permissible weight may cause damage and result in functional impairment of the hinges

Δ Weight

A: Appliance door height including hinges in mm

B: Undamped hinge, unit front in kg

C: Damped hinge, unit front in kg

D: Additional possible load in kg with heavy load kit

A	B	C	D
1500-1750	22	22	
720-1400	19	19	B+5 / C+5
A1	15	19	
A2	15	19	

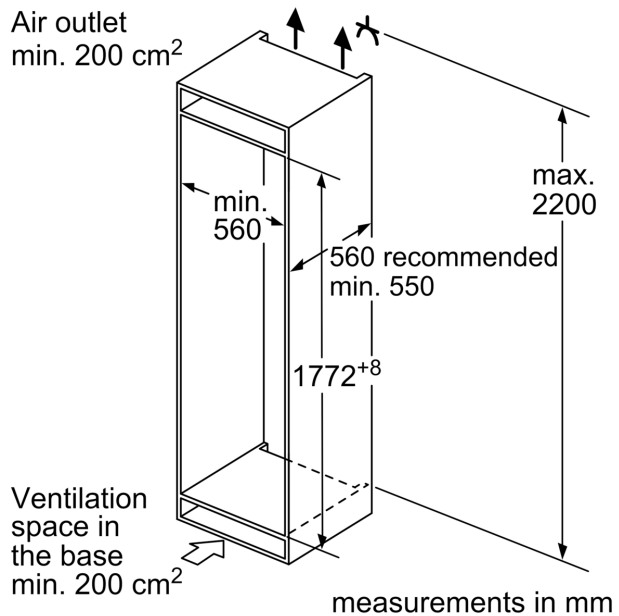

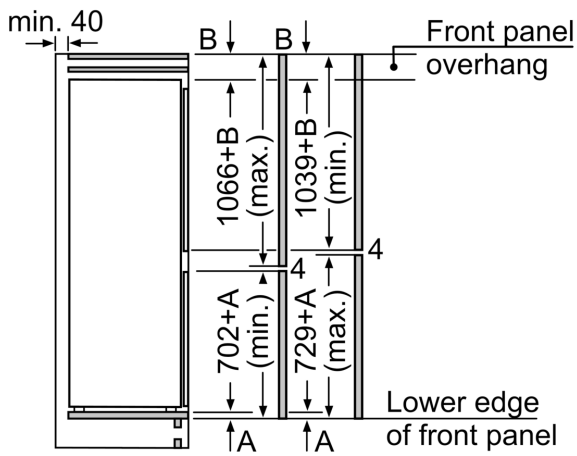

The specified unit door dimensions are valid for a door gap of 4 mm.  
 measurements in mm

measurements in mm  
 Recommended gap dimensions for flat hinges

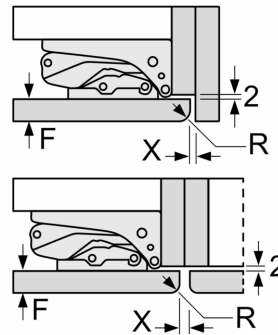

F	R	X
16-19	0-3	2.5
20	0-1	3
	2-3	2.5
21	0-1	3
	2-3	2.5
22	0	4
	1	3.5
	2-3	3

The gap dimensions recommended in the table must be adhered to in order to ensure that appliance doors do not collide with anything when they are opened, and to avoid causing damage to kitchen units.