

## iQ300, Built-in fridge-freezer with freezer at bottom, 177.2 x 54.1 cm, sliding hinge KI87VVS30G



A++



built-in-fridge-freezer with energy efficiency class A++ and 3 practical freezer Fresh Boxes

- ✓ Less frost formation and faster defrosting with lowFrost.
- ✓ LED light – Ample, even lighting helps you check what's in your fridge faster.
- ✓ The bigBox offers plenty of space to store and stack large frozen items efficiently.
- ✓ The fruit and vegetables stay crispy in the Fresh Box with wavy bottom.
- ✓ superFreezing – Quick-freeze even large amounts of food.

### Features

#### Technical Data

Construction type : Built-in  
 Door panel options : Not possible  
 Width of the appliance : 541 mm  
 Depth of the product : 545 mm  
 Required niche size for installation (HxWxD) : 1775.0 x 560 x 550 mm  
 Net weight : 61.595 kg  
 Connection rating : 90 W  
 Fuse protection : 13 A  
 Door hinge : Right reversible  
 Voltage : 220-240 V  
 Frequency : 50 Hz  
 Approval certificates : CE, VDE  
 Length of electrical supply cord : 230 cm  
 Storage Period in Event of Power Failure (h) : 26 h  
 Number of compressors : 1  
 Number of independent cooling systems : 1  
 Interior ventilator : No  
 Reversible Door Hinge : Yes  
 Number of Adjustable Shelves in fridge compartment (Stck) : 4  
 Shelves for Bottles : No  
 EAN code : 4242003694275  
 Brand : Siemens  
 Product name / Commercial code : KI87VVS30G  
 Energy consumption annual - NEW (2010/30/EC) : 227.00 kWh/annum  
 Refrigerator Net capacity - NEW (2010/30/EC) : 209 l  
 Freezer Net capacity - NEW (2010/30/EC) : 63 l  
 Frost free system : No  
 Freezing capacity) - NEW (2010/30/EC) : 3 kg/24h  
 Climate class : SN-T  
 Noise level : 38 dB(A) re 1 pW  
 Installation type : Full-integrated

#### Included accessories

- 2 x cold accumulator
- 2 x egg tray
- 1 x ice cube tray



**iQ300, Built-in fridge-freezer with  
freezer at bottom, 177.2 x 54.1 cm,  
sliding hinge  
KI87VVS30G**

#### Features

##### Performance and Consumption

- Energy Efficiency Class: A++
- Energy Efficiency Class: A++ kWh/yr: 0.621 kWh
- Total net capacity: 272 l litres
- Net fridge capacity: 209 litres
- Net freezer capacity: 63 litres
- Noise level dB(A) re 1 pW: 38

##### Design features

- Manual defrost freezer
- Right hinged door, door reversible
- Electronic control (LED chain)
- Removable magnetic door seals - easy to clean

##### Food freshness system

- 1 vegetable/salad container
- 
- VitaControl - constant temperature by intelligent sensor technology - Constant temperature control by intelligent sensor technology
- 1 compressor/1 cooling circuit

##### Key features - Fridge section

- Automatic defrost in fridge section
- Bright interior LED fridge light
- 
- 5 safety glass shelves in fridge compartment of which 4 are height adjustable

##### Key features - Freezer section

- 4 star rating
- 2 freezer drawers
- Freezing capacity in 24 hours: 3 kg
- Maximum freezer storage time in power failure: 26 hours
- 2 x cold accumulator, 3 x egg tray, 2 x ice cube tray

##### Functions

- superFreeze function with automatic deactivation

##### Dimension and installation

- easy Installation
- Connection value 90 W
- Dimensions: 177.2 cm H x 54.1 cm W x 54.5 cm D
- Niche Dimensions: 177.5 cm H x 56 cm W x 55 cm D
- Climate class SN-T (suitable for ambient temperatures between 10 to 43°C)

**iQ300, Built-in fridge-freezer with  
freezer at bottom, 177.2 x 54.1 cm,  
sliding hinge  
KI87VVS30G**

Dimensioned drawings

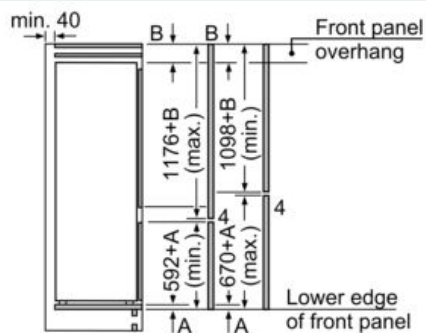
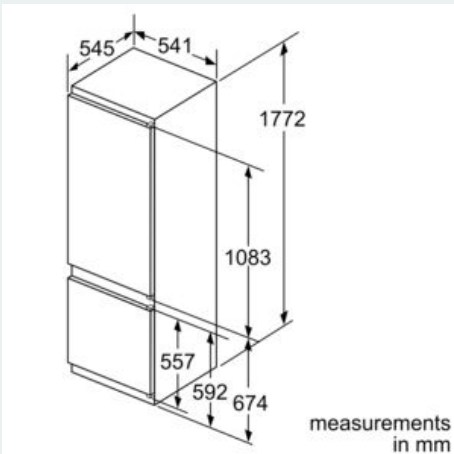
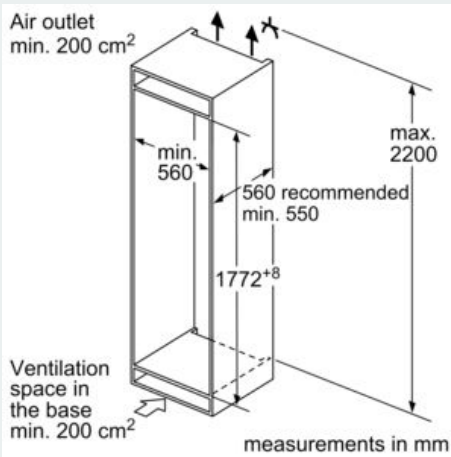

The specified unit door dimensions  
are valid for a door gap of 4 mm.  
measurements in mm