

## iQ700, Built-in fridge-freezer with freezer at bottom, 177.2 x 55.8 cm KI84FPF30

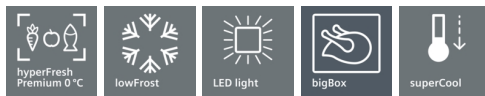

A++



Premium refrigerator-freezer with hyperFresh premium 0°C to keep food fresher for longer.

- ✓ hyperFresh Premium 0°C –#Optimal storage for all your fresh ingredients.
- ✓ Less frost formation and faster defrosting with lowFrost.
- ✓ LED light – Ample, even lighting helps you check what's in your fridge faster.
- ✓ The bigBox offers plenty of space to store and stack large frozen items efficiently.
- ✓ The superCooling button reduces the temperature for a set time, to quickly cool down fresh food items.

### Features

#### Technical Data

Construction type : Built-in  
 Door panel options : Not possible  
 Width of the appliance : 558 mm  
 Depth of the product : 545 mm  
 Required niche size for installation (HxWxD) : 1775.0 x 560 x 550 mm  
 Net weight : 69.384 kg  
 Connection rating : 90 W  
 Fuse protection : 10 A  
 Door hinge : Right reversible  
 Voltage : 220-240 V  
 Frequency : 50 Hz  
 Approval certificates : CE, VDE  
 Length of electrical supply cord : 230 cm  
 Storage Period in Event of Power Failure (h) : 21 h  
 Number of compressors : 1  
 Number of independent cooling systems : 2  
 Interior ventilator : No  
 Reversible Door Hinge : Yes  
 Number of Adjustable Shelves in fridge compartment (Stck) : 2  
 Shelves for Bottles : No  
 EAN code : 4242003829059  
 Brand : Siemens  
 Product name / Commercial code : KI84FPF30  
 Energy consumption annual - NEW (2010/30/EC) : 229.00 kWh/annum  
 Refrigerator Net capacity - NEW (2010/30/EC) : 159 l  
 Freezer Net capacity - NEW (2010/30/EC) : 75 l  
 Frost free system : No  
 Freezing capacity) - NEW (2010/30/EC) : 8 kg/24h  
 Climate class : SN-ST  
 Noise level : 34 dB(A) re 1 pW  
 Installation type : Full-integrated

#### Included accessories

- 2 x cold accumulator
- 3 x egg tray
- 1 x ice cube tray with lid
- 1 x bottle holder in door tray



## iQ700, Built-in fridge-freezer with freezer at bottom, 177.2 x 55.8 cm KI84FPF30

### Features

#### Performance and Consumption

- Energy Efficiency Class: A++ kWh/yr: 0.627 kWh
- Total net capacity: 234 l litres
- Net fridge capacity: 159 litres
- Net freezer capacity: 75 litres
- Noise level dB(A) re 1 pW: 34

#### Design features

- Manual defrost freezer
- Right hinged door, door reversible
- LED display for fridge and freezer
- Removable magnetic door seals - easy to clean

#### Food freshness system

- 1 hyperFresh premium 0°C box with adjustable humidity - keeps fruit and vegetables fresher for longer.
- 
- VitaControl - constant temperature by intelligent sensor technology - Constant temperature control by intelligent sensor technology
- Twin evaporators allows independent temperature control and ensures there is no transference of humidity between the fridge and freezer cavity.

#### Key features - Fridge section

- Capacity near 0°C section: 56 l
- Bright interior LED fridge light
- 
- 3 safety glass shelves (2 height adjustable)
- Super Cooling: automatic deactivation

#### Key features - Freezer section

- Removable safety glass shelves for extra space
- 4 star rating
- 3 transparent freezer drawers, 1 bigBox
- Freezing capacity in 24 hours: 8 kg
- Maximum freezer storage time in power failure: 21 hours
- 3 x egg tray, 1 x ice cube tray, 1 x bottle holder in door tray, 2 x cold accumulator

#### Functions

- Freezer malfunction warning signal: Optical and acoustical
- superFreeze function with automatic deactivation
- Acoustic open door warning system

#### Dimension and installation

- easy Installation
- Connection value 90 W
- Dimensions: 177.2 cm H x 55.8 cm W x 54.5 cm D
- Niche Dimensions: 177.5 cm H x 56 cm W x 55 cm D
- Climate class SN-ST (suitable for ambient temperatures between 10 to 38°C)

**iQ700, Built-in fridge-freezer with freezer at bottom, 177.2 x 55.8 cm  
KI84FPF30**

Dimensioned drawings

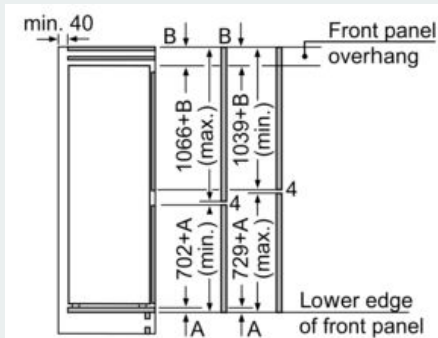
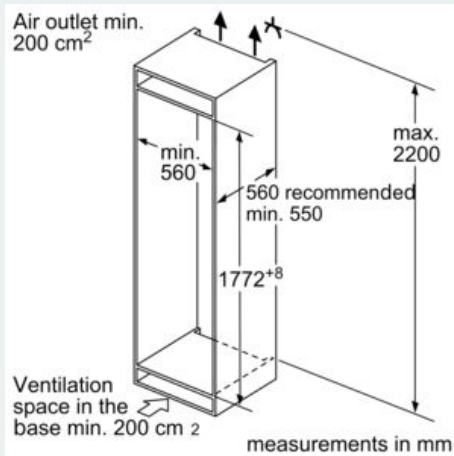
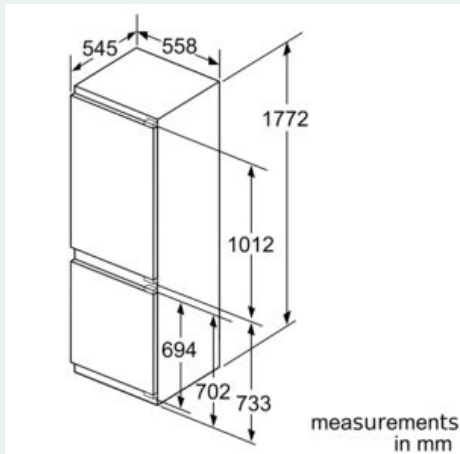

The specified unit door dimensions are valid for a door gap of 4 mm.  
measurements in mm

measurements in mm  
Recommended gap dimensions for flat hinges

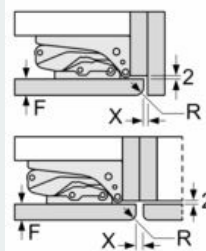

F	R	X
16-19	0-3	2.5
20	0-1	3
	2-3	2.5
21	0-1	3
	2-3	2.5
22	0	4
	1	3.5
	2-3	3

The gap dimensions recommended in the table must be adhered to in order to ensure that appliance doors do not collide with anything when they are opened, and to avoid causing damage to kitchen units.