

**Series 4, Built-in fridge-freezer with freezer at bottom, 193.5 x 70.8 cm, flat hinge
KBN96VFE0G**



KSZGGM00 Butter box

Built-in fridge freezer with XXL capacity and VitaFresh near <0°C>: big boost in fridge capacity and ideal storage conditions for all your food.

- **Two cooling systems:** separately controllable fridge and freezer compartments

Energy Efficiency Class:	E
Average annual energy consumption in kilowatt hour per year (kWh/a):	256 kWh/annum
Sum of volume of frozen compartments:	98 l
Sum of volume of chill compartments:	285 l
Airborne acoustical noise emissions :	34 dB(A) re 1pW
Airborne acoustical noise emission class:	B
Built-in / Free-standing:	Built-in
Door panel options:	Not possible
Height:	1935 mm
Width of the appliance:	708 mm
Depth:	548 mm
Min. required niche size for installation (HxWxD): ..	1940 x 710 x 560 mm
Net weight:	70.2 kg
Fuse protection:	10 A
Door hinge:	Right reversible
Voltage:	220-240 V
Frequency:	50 Hz
Length electrical supply cord:	230.0 cm
Number of compressors:	1
Number of independent cooling systems:	2
Interior ventilator:	No
Reversible Door Hinge:	Yes
Number of Adjustable Shelves in fridge compartment:	4
Shelves for Bottles:	Yes
Frost free system:	Freezer
Installation typology:	N/A



Series 4, Built-in fridge-freezer with freezer at bottom, 193.5 x 70.8 cm, flat hinge KBN96VFE0G

Built-in fridge freezer with XXL capacity and VitaFresh near <0°C>: big boost in fridge capacity and ideal storage conditions for all your food.

consumption depends on usage/position of the appliance.

Dimension and installation

- Dimensions: 193.5 cm H x 70.8 cm W x 54.8 cm D
- Niche Dimensions: 194 cm H x 71 cm W x 56 cm D
- Length of power cord: 230 cm

Country Specific Options

Design features

- Built-in fridge-freezer
- NO_FROST_NEU_BL, never have to defrost ever again
- Right hinged door, door reversible
- Heavy load hinge set
- Height adjustable front feet
- Bright interior LED fridge light in fridge section
- Separate, electronic temperature control with LED display
- Home Connect: iService Remote, Remote Monitoring and Control with Wi-Fi connectivity

Functions

- Automatic defrost fridge
- Two separate cooling circuits allow independent temperature control and prevents the transference of humidity between the fridge and freezer cavity
- Super Cooling: automatic deactivation
- Acoustic alarm, Optical and acoustical, acoustic for Fridge and Freeze

Food freshness system

- 1 VitaFresh drawer with humidity control - Fruits and vegetables retain vitamins and stay fresh for longer

Key features - Fridge section

- 5 safety glass shelves in fridge compartment of which 4 are height adjustable
- Door shelves in fridge door: 1 large and 3 small.
- Metal bottle rack

Key features - Freezer section

- 3 freezer drawers

Additional features

- 3 x egg tray, 1 x ice cube tray

Performance and Consumption

- Climate Class: SN-ST
- Total Volume : 383 l
- Net Fridge Volume : 285 l
- Net Freezer Volume : 98 l
- Annual Energy Consumption: 256 kWh/a
- Noise Level : 34 dB , EU19_Noise emission class_D: B
- Temperature rise time : EU19_Temperature rise time_D: 13 H
- Freezing capacity 24h : 9.5 kg
- 220 - 240 V
- EU19_EEK_D: E
- EU19_Fast freezer facility_D
- Based on the results of the standard 24-hour test. Actual

**Series 4, Built-in fridge-freezer with
freezer at bottom, 193.5 x 70.8 cm,
flat hinge
KBN96VFE0G**

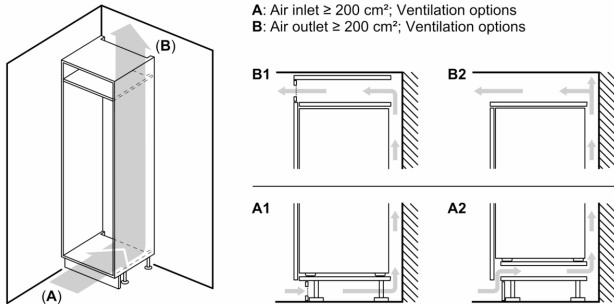

Measurements in mm

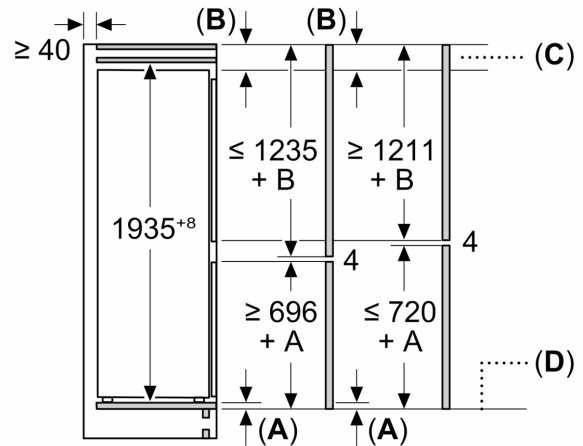

C: Front panel overhang

D: Lower edge of front panel

Measurements in mm

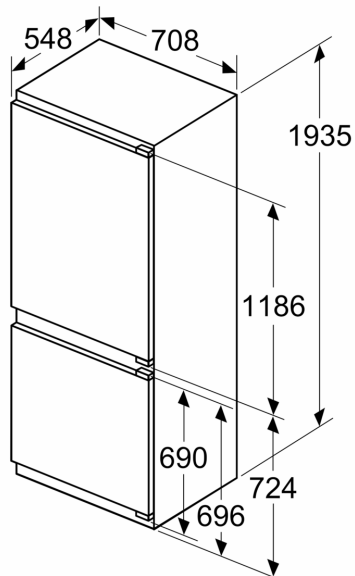

Measurements in mm

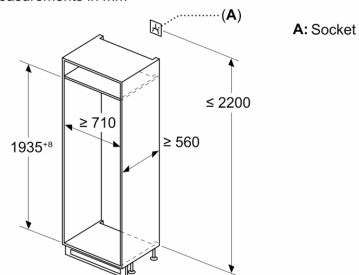

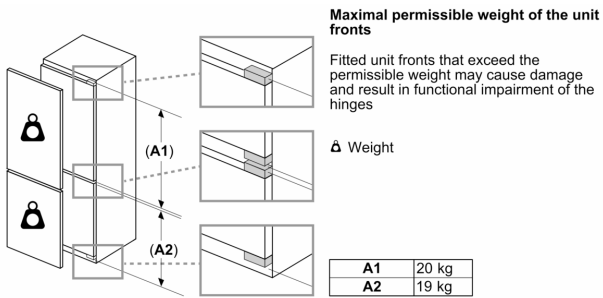

measurements in mm
Recommended gap dimensions for flat hinges

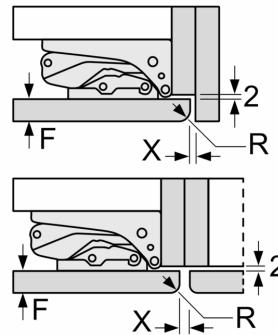

F	R	X
16-19	0-3	2.5
20	0-1	3
	2-3	2.5
21	0-1	3
	2-3	2.5
22	0	4
	1	3.5
	2-3	3

The gap dimensions recommended in the table must be adhered to in order to ensure that appliance doors do not collide with anything when they are opened, and to avoid causing damage to kitchen units.