

iQ100, Built-in fridge-freezer with freezer at bottom, 193.5 x 69.1 cm, sliding hinge KB96NNSE0



KSZGGM00 Butter box

Built-in fridge freezer with 45 percent extra space and hyperFresh <0°C>: ideal storage conditions for all your food and XXL capacity to shop in bulk.

- ✓ hyperFresh – The extra-large drawer for your fruit and vegetables.
- ✓ safetyGlass shelves – Extra strong and easy to clean.
- ✓ Made in Germany – The promise of top quality, state-of-the-art design and innovative features.
- ✓ Noise Class B: appliances that are as quiet as rustling leaves.

Energy Efficiency Class: E

Energy Efficiency Class:	E
Average annual energy consumption in kilowatt hour per year (kWh/a):	256 kWh/annum
Sum of volume of frozen compartments:	98 l
Sum of volume of chill compartments:	285 l
Airborne acoustical noise emissions :	34 dB(A) re 1pW
Airborne acoustical noise emission class:	B
Built-in / Free-standing:	Built-in
Door panel options:	Not possible
Height:	1935 mm
Width of the appliance:	691 mm
Dimensions:	548 mm
Min. required niche size for installation (HxWxD):	1940 x 710 x 560 mm
Weight:	65.9 kg
Fuse protection:	10 A
Door opening:	Right reversible
Nominal power:	220-240 V
Frequency:	50 Hz
Length electrical supply cord:	230.0 cm
Number of compressors:	1
Number of independent cooling systems:	2
Interior ventilator:	No
Reversible Door Hinge:	Yes
Number of Adjustable Shelves in fridge compartment:	4
Shelves for Bottles:	No
Frost free system:	Freezer
Installation type:	Fully integrated



iQ100, Built-in fridge-freezer with freezer at bottom, 193.5 x 69.1 cm, sliding hinge KB96NNSE0

- noFrost freezer, Built-in fridge freezer
- Sliding hinge - Easy installation, softClosing door: No

Performance and Consumption

- EU19_EEK_D: E
- Total Volume : 383 l
- Annual Energy Consumption: 256 kWh/a
- Noise Level : 34 dB , EU19_Noise emission class_D: B

Functions

- LED fridge light with Soft Start in fridge section
- Built-in fridge freezer

Design features

- NO_FROST_NEU_BL, never have to defrost ever again
- Heavy load hinge set
- EU19_Fast freezer facility_D
- Home Connect: iService Remote, Remote Monitoring and Control with Wi-Fi connectivity
- Electronic control (2 LED chains)
- Twin evaporators allows independent temperature control and ensures there is no transference of humidity between the fridge and freezer cavity.
- Super Cooling: automatic deactivation
- acoustic alarm, Optical and acoustical door open warning system, acoustic for Fridge and Freeze
- Automatic defrost in fridge section

Design features

- Net Fridge Volume : 285 l
- 5 safety glass shelves of which 4 are height adjustable
- Door shelves in fridge door: 1 large and 3 small.

Freshness System

- 1 hyperFresh box with integrated humidity control

Food freshness system

- Net Freezer Volume : 98 l
- Freezing capacity 24h : 9.5 kg
- Temperature rise time : EU19_Temperature rise time_D: 12 H
- 3 freezer drawers

Dimension and installation

- Dimensions: 193.5 cm H x 69.1 cm W x 54.8 cm D
- Niche Dimensions: 194 cm H x 71 cm W x 56 cm D

Key features - Fridge section

- Right hinged door, door reversible
- Height adjustable front feet
- Length of power cord:230 cm
- Climate Class: SN-ST
- 220 - 240 V

Key features - Freezer section

- 3 x egg tray, 2 x ice cube tray

Country Specific Options

- Based on the results of the standard 24-hour test. Actual consumption depends on usage/position of the appliance.

Design features

Dimension and installation

Additional features

- none

**iQ100, Built-in fridge-freezer with
freezer at bottom, 193.5 x 69.1
cm, sliding hinge
KB96NNSE0**

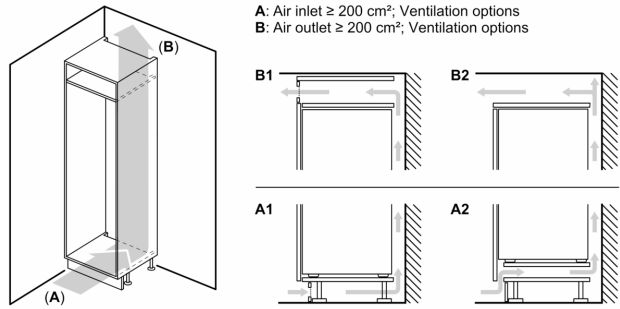

Measurements in mm

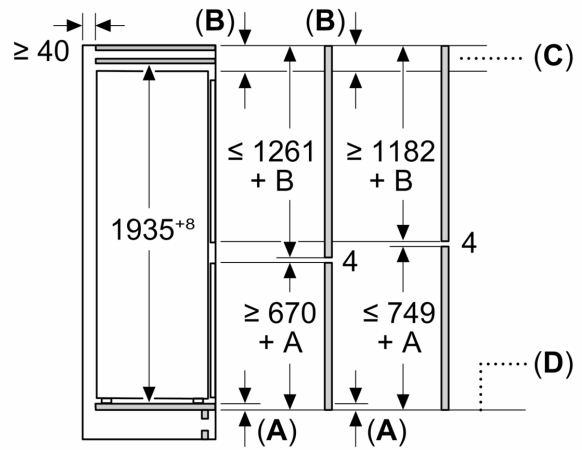

C: Front panel overhang

D: Lower edge of front panel

Measurements in mm

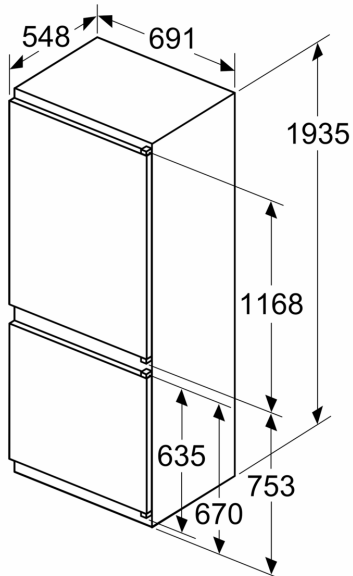

Measurements in mm

