

iQ700, American side by side, 177.8 x 91.2 cm, Black stainless steel KA92DHXFP



Side-by-Side fridge freezer with innovative noFrost technology and cameras: the cameras in the fridge let you check the content of your fridge from wherever you are, whenever you want.

- ✓ Camera in the Fridge: Check the contents of your fridge wherever you are.
- ✓ Storage Guide: Easily find the best possible place for each individual food.
- ✓ The hyperFresh plus Box with adjustable humidity keeps fruit and vegetables fresh for longer.
- ✓ noFrost – Never defrost your freezer again.
- ✓ Home Connect – Control your smart fridge no matter where you are.

Features

Technical Data

Energy Efficiency Class: F
 Average annual energy consumption in kilowatt hour per year (kWh/a): 419 kWh/annum
 Sum of volume of frozen compartments: 209 l
 Sum of volume of chill compartments: 376 l
 Airborne acoustical noise emissions : 42 dB(A) re 1 pW
 Airborne acoustical noise emission class: D
 Construction type: Free-standing
 Door panel options: Not possible
 Height: 1778 mm
 Width of the product: 912 mm
 Depth of the product: 732 mm
 Net weight: 141.8 kg
 Connection rating: 190 W
 Fuse protection: 10 A
 Door hinge: Left & Right
 Voltage: 220-240 V
 Frequency: 50-60 Hz
 Approval certificates: CE, VDE
 Length of electrical supply cord: 240 cm
 Storage Period in Event of Power Failure (h): 8 h
 Number of compressors: 1
 Number of independent cooling systems: 2
 Interior ventilator: No
 Reversible Door Hinge: No
 Number of Adjustable Shelves in fridge compartment (Stck): 3
 Shelves for Bottles: Yes
 Capacity of Water Tank: 1.0 l
 EAN code: 4242003860946
 Brand: Siemens
 Product name / Commercial code: KA92DHXFP
 Installation type: N/A

Included accessories

- 2 x cold accumulator
- 1 x connection hose
- 1 x egg tray

Optional accessories

- KS63Z000 water hose extension



iQ700, American side by side, 177.8 x 91.2 cm, Black stainless steel KA92DHXFP

Features

Design features

- Brushed aluminium vertical door handle

Functions

- NoFrost, never have to defrost ever again
- Electronic control (external in-door LCD display)
- Twin evaporators allows independent temperature control and ensures there is no transference of humidity between the fridge and freezer cavity.
- Super Cooling: automatic deactivation
- superFreeze function with automatic deactivation
- Freezer malfunction warning signal: optical and acoustical
- optical and acoustical Failure memory function, Optical and acoustical
- Acoustic open door warning system

Ice and Water

- In-door ice and water dispenser: chilled water, crushed ice, ice cubes, water filter included. Dispenser features: child lock, LED light
- Automatic ice cube maker
- Internal water filter

Food freshness system

- multiAirflow cooling - improves circulation of air around the fridge
-
- coolBox - extra cold fridge drawer. Ideal to store meat and fish.
- 1 x humidity controlled vegetable/salad drawer on telescopic rails
- 1 x hydroFresh drawer - humidity controlled vegetable/salad container on telescopic rails for prolonged storage

Key features - Fridge section

- 1 dairy compartment in door
- Door shelves in fridge door: 2 large and 3 small.
- Bright interior LED fridge light
-
- Bottle rack

Key features - Freezer section

- 3 freezer shelves of which 2 are height adjustable
- 2 freezer drawers
- 4 door storage compartments
- Bright interior LED freezer light
- 2 x cold accumulator, 1 x connection hose, 3 x egg tray

Dimension and installation

- Connection Length (water supply): 300 cm
- Connection value 190 W
- 220 - 240 V
- Dimensions: 177.8 cm H x 91.2 cm W x 73.2 cm D
- Based on the results of the standard 24-hour test. Actual consumption depends on usage/position of the appliance.
- To achieve the declared energy consumption, the attached distanceholders have to be used. As a result, the appliance depth increases by about 3.5 cm. The appliance used without the distance holder is fully functional, but has a slightly higher energy consumption.
- premium door design Black steel - anti-fingerprint finish
- Freestanding \geq 60cm width

Performance and Consumption

- EU19_EEK_D: F
- Total Volume : 585 l
- Net Fridge Volume : 376 l
- Net Freezer Volume : 209 l
- Freezing capacity 24h : 15 kg
- Annual Energy Consumption: 419 kWh/a
- Climate Class: SN-T
- Noise Level : 42 dB , EU19_Noise emission class_D: D
- Temperature rise time : EU19_Temperature rise time_D: 8.5 H

**iQ700, American side by side, 177.8 x 91.2 cm, Black stainless steel
KA92DHXFP**

Dimensioned drawings

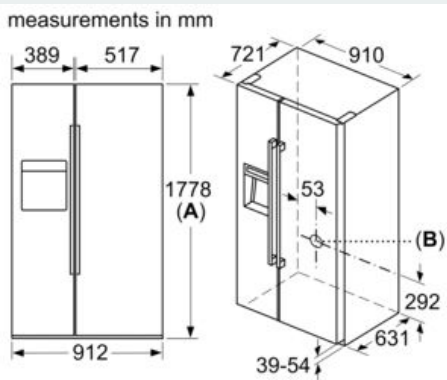

A: Front is adjustable from 1769 to 1784
B: Water connection to the appliance

