

iQ700, Induction hob with integrated ventilation system, 80 cm, Matt black, EX87BNX68E



Included accessories

1 x Slider for unducted recirculation, 1 x Clean Air Plus odor filter

Optional accessories

HZ32WA00 wireless roastingSensor, HZ39050 Wireless temperature sensor for cooktop, HZ390522 Griddle Plate, HZ9FE280 Iron pan Ø 18 / 28 cm, HZ9FF010 Flex Pan, large, HZ9FF030 Flex Pan set, 3 pcs., HZ9FF040 Flex Pan set, 4 pcs., HZ9SE030 Set of 2 pots and 1 pan, HZ9SE040 4 pieces Set, HZ9SE060 6 pieces Set, HZ9TY010 Teppan Yaki, HZ9VDKE1 Exhaust kit, HZ9VDKR0 Recirculation kit 2 L-bow (70cm), HZ9VDKR1 Recirculation kit S and L-bow (60cm), HZ9VDSB1 90° flat duct bend horizontal, HZ9VDSB2 90° flat duct L vertical, HZ9VDSB3 90° flat duct M vertical, HZ9VDSB4 90° flat duct S vertical, HZ9VDSI0 Adapter round-flat, HZ9VDSI1 90° Adapter round-flat, HZ9VDSM1 Straight tube 500mm, HZ9VDSM2 Straight tube 1000mm, HZ9VDS1 Connector sleeve (female), HZ9VDS2 Flexibel connecting piece DN 150 flat, HZ9VEDU0 Acoustics Filter, HZ9VRCR1 Clean Air Plus odor filter (replacement), HZ9VRPD1 Plinth Diffusor

Design hob with a fully integrated, totally flush air-inlet.

- ✓ Matt Edition: fewer visible scratches
- ✓ Matt Edition: The matt finish is fingerprint resistant.
- ✓ Matt Edition: Fast cleaning without streaks.
- ✓ flexInduction – Smart cooking zone that adapts to your cookware.
- ✓ Blue dual lightSlider – Elegant touch and slide control.

Features

Technical Data

Product name/family: Cooking zone ceramic
 Built-in / Free-standing: Built-in
 Source of energy: Electric
 Number of cooking zones: 4
 Required niche size for installation (HxWxD):223 x 750-750 x 490-490 mm
 Width of the appliance: 812 mm
 Dimensions: 223x812x520 mm
 Dimensions of the packed product (HxWxD):440x940x660 mm
 Weight: 26.9 kg
 Gross weight: 31.6 kg
 Residual heat indicator: Separate
 Location of control panel: Front
 Basic surface material: Ceramic
 Color of surface: Matt black
 Length electrical supply cord: 110 cm
 Sealed Burners: No
 heating with booster:All
 Power of 2nd heating element (kW): 3300.0 W
 Number of speed settings: 17-stage + 2 intensive
 Maximum output air extraction:500 m³/h
 Boost position output recirculating:595.0 m³/h
 Maximum output recirculating air: 499 m³/h
 Boost position air extraction:622 m³/h
 Noise level: 69 dB(A) re 1pW
 Odour filter: No
 Ventilation type:Convertible
 Clean filter reminders: Yes
 Nominal power: 220-240/380-415 V
 Frequency:50-60 Hz
 Included accessories: 1 x Slider for unducted recirculation, 1 x Clean Air Plus odor filter



iQ700, Induction hob with integrated ventilation system, 80 cm, Matt black, EX87BNX68E

Features

- 80 cm: space for 4 pots or pans.

Flexibility of cooking zones

- 2 flexInduction zones: use cookware of any shape or size anywhere within the 40cm long zone.
- Cooking zone front left: 200 mm, 240 mm, 2.2 KW (max. power 3.7 KW)
- Cooking zone rear left: 200 mm, 240 mm, 2.2 KW (max. power 3.7 KW)
- Cooking zone rear right: 200 mm, 240 mm, 2.2 KW (max power 3.7 KW)
- Cooking zone front right: 200 mm, 240 mm, 2.2 KW (max. power 3.7 KW)

Usage convenience

- Directly control the power on the two blue illuminated touch bars (invisible when switched off).
- 17 power levels: precisely adapt the heat with 17 power levels (9 main levels and 8 intermediate levels).
- Keep warm function: yes: Keep dishes warm at preset low power level.
- Switch-off timer: switches off the cooking zone at the end of the time set (e.g. for boiled eggs).
- Count-down timer: an alarm sounds at the end of the time set (e.g. for pasta).
- Count-up timer: shows how much time has passed since starting the timer (e.g. for potatoes).

Time saving & efficiency

- Power boost setting
- : boil water faster thanks to 50% more energy than at the highest standard level.
- panBoost: heat up pans faster than at the highest standard level while protecting the pan coating.
- Intelligent flexZones: when placing large cookware on the Flex zone, the hob automatically connects two cooking zones into a large continuous one.
- powerMove plus: increase or decrease the power level simply by moving the pot forwards or backwards.
- flexMotion: when moving a pot to a different cooking zone, this feature transfers all previous settings to the new zone at the touch of a button.
- When moving a pot on the Flex zone, the settings adjust instantly and the cooking zone adapts to the size of the cookware.
- Automatic zone selection: when switched on, the hob automatically selects the cooking zone on which a new cookware is placed.
- quickStart function: when switching on, the hob automatically selects the cooking zone with cookware (when placed on a zone whilst the hob is off).
- reStart function: in case of unintentional switch-off, this feature restores all previous settings by switching on the hob again within 4 seconds.

Cooking assistance

- cookingSensor Plus ready (sensor available as additional purchase): prevents overboiling of pots with the automatic temperature regulation of the sensor (attached to the pot).
- fryingSensor Plus with 5 frying and 5 cooking levels: prevents overcooking with the automatic temperature regulation of the integrated sensor.
- Dish assistant: easily find the right temperature setting for a certain dish via the home connect app.

Connectivity

- Home Connect - enables Remote Monitoring no matter where you are, with the easy-to-use Home Connect App: check if the hob is switched off even when not at home, and find recipes or additional functions in the Home Connect app.

Design

- Helios LED Matt: elegant, matt glass ceramic design which is less susceptible to visible scratches and fingerprints.
- Design - line: Side profiles, Studio Line, Frame / profile colour: black anodized
- Siemens studioLine exclusive zone printing: minimalistic design thanks to dark colour of zone printing. Siemens studioLine exclusive zone printing: minimalistic design thanks to dark colour of zone printing.

Safety

- 2 stage residual heat indicators: indicates which cooking zones are still hot or warm.
- Control panel lock: prevent unintended activation of the hob.
- Control panel pause: wipe overboiled liquids without unintentionally changing settings (blocking all touch buttons for 30 seconds).
- Main on/off switch: switch off all cooking zones at the touch of a button.
- Automatic safety switch off: for safety reasons, heating stops after a preset time if not used.
- Energy Consumption Display: shows the electricity consumption of the last cooking process.

Installation

- Dimensions of the product (HxWxD mm): 223 x 812 x 520
- Required niche size for installation (HxWxD mm) : 223 x 750 x (490 - 490)
- Min. worktop thickness: 16 mm
- Connected load: 7.4 KW
- Connection current management (20, 16, 13, 10 Amps options): limit the maximum power if needed (depends on fuse protection of electric installation).
- Power cord: 1.1 m, Cable included in packaging

Accessories

- Clean Air Plus odor filter, Slider for unducted recirculation included
- Suitable for installation into a 60 cm base cabinet

Integrated ventilation downdraft system

- Induction cooktop with fully integrated high-performance downdraft

Features

extractor.

- Suitable for ducted or recirculated extraction configuration (incl. differentiated software modes). Installation accessories for unducted recirculation, among these four cleanAir Plus odour filters and a telescopic slider element, are included in the cooktop. Accessories for other installation options are available, details in the planning notes.
- Aesthetically integrated fully flush air intake design with floating, heat resistant glass ceramics element for free movement and placement of cookware.
- Ventilation system with 17 electronically controlled fan power levels and 2 Boost-/Intensive fan power levels (with automatic revert) via Dual lightSlider user interface. Sensor-based, smart, fully automatic mode of ventilation system:
- - Automatic switch-on of ventilation system when a cooking zone is used.
- - Sensor-based and cooktop-based, fully-automatic adjustment of power levels via advanced algorithm for maximum convenience.
- - 3 possible sensitivity modes of algorithm for maximum convenience (Low-noise oriented, balanced, performance-oriented).
- - Automatic delayed shut-off after cooking to erase residual odors after cooking (in specific ultra low-noise fan level, 12min in ducted extraction, 30min in recirculated extraction, can be shut-off manually).
- - Manual control possible via Dual lightSlider.
- High-performance, low-noise blower with energy-efficient BLDC-technology. High extraction rates at very low noises with pleasant noise frequencies through psycho-acoustically and aerodynamically optimized interior with enclosed, non-visible blower. Highly pressuredrop resistant even with longer and more complex ductings.
- Easy-to-detach and easy-to-clean grease filter and liquid collector unit:
- - Convenient one-hand removal of unit via floating glass ceramics handle.
- - Integrated, large-scale, high performance stainless-steel grease filters with 12 filtration layers and one black top layer for enhanced aesthetic integration. Grease filtration efficiency of 94 %.
- - All parts of the unit are easy-to-clean, fully dishwasher safe and heat resistant.
- - (Upper) Liquid collector unit with 200ml of capacity for standard accidental spillages or cooking condensate.
- - Powerful drainage system for spillages that exceed 200ml of liquids.
- - Liquid safety collector with additional capacity of 700ml for more severe accidental situations. Dishwasher safe. Easily accessible and detachable from below.
- - Overall capturing capacity of 900ml (200ml + 700ml).
- - Watertight blower system.
- Ventilation system performance:
- - Extraction performance in ducted extraction (according to EN 61591): min. normal setting 154 m³/h , max. normal setting 500 m³/h , max. Boost-/Intensive setting 622 m³/h .
- - Extraction performance in recirculated extraction (according to EN 61591): min. normal setting 132 m³/h , max. normal setting 499 m³/h , max. Boost-/Intensive setting 595 m³/h.
- - Noise level in ducted extraction (Sound power level according to EN 60704-3): min. normal setting 42 dB re 1 pW, max. normal setting 69 dB re 1 pW, max. Boost-/Intensive setting 74 dB re 1 pW.
- - Noise level in recirculated extraction (Sound power level according

to EN 60704-3.): min. normal setting 41 dB re 1 pW, max. normal setting 68 dB re 1 pW, max. Boost-/Intensive setting 72 dB re 1 pW.

- - Grease filter efficiency (according to EN 61591) 94 %.
- Consumption data and energy efficiency (according to Regulation (EU) No 65/2014):
- - Energy Efficiency Class: B (at a range of energy efficiency classes from A+++ to D).
- - Fluid Dynamic Efficiency: A .
- - Average energy consumption: 57 .
- - Grease filtration efficiency class: B .
- - Noise min. normal setting & max. normal setting: 42 dB & 69 dB .
- For recirculation configuration: 2 x 2 battery of directly integrated, high-performance cleanAir Plus odour filters.
- - Optimised odour reduction performance for cooking applications with complex odour molecules (e.g. fish).
- - Large scale filter surface with high odour reduction capabilities.
- - Anti-pollen functionality: The filter retains an extremely high amount of airborne pollen and deactivates allergens which are retained by the filter.
- - Lifetime of 360 hours of cooking (non-regenerative).
- - Low-noise filters with optimised psycho-acoustics.
- - Easy-to-access and easy-to-remove from above.
- - Saturation indications for cleanAir odour filter via user interface notification and via the Home Connect app with a convenient replenishment re-order option (replenishment cleanAir filter set HZ9VRCR0).
- For ducted extraction configuration: 2 x 2 sets of directly integrated, high-performance low-noise acoustic filters for significantly lower noise and improved psycho-acoustics.

Planning & installation notes

- Suitable for ducted or recirculated extraction installations in 4 different options (unducted, partly and fully ducted recirculation or ducted extraction). Installation accessories for unducted recirculation, among these four cleanAir Plus odour filters and a telescopic slider element, are included in the cooktop. The included accessories allow easy and quick installations and can be planned in all worktop depths ≥ 60 cm. For other types of installation, one of the following accessory kits is recommended:
- HZ9VDKR1 for partly-ducted recirculation in worktops of ≥ 60 cm depth with max. worktop height of 960 mm. HZ9VDKR0 for partly-ducted recirculation in worktops of ≥ 70 cm depth with max. worktop height of 960 mm.
- HZ9VDKE1 as starter kit for ducted extraction in worktops of ≥ 60 cm depth.
- To complete the fully ducted extraction or to do any other individual recirculation planning different ducting accessories are available.
- Planning suggestions:
- - Installation is possible in island as well as wall oriented configurations.
- The product and its accessories comply with the Needle Flame Test (according to IEC 60695-11-5) and the V2 flammability class (according to UL94).
- - The max. immersion depth is 223 mm below worktop surface.
- - The appliance must be freely accessible from below (i.e. for accessing the lower liquid safety collector).
- - No false floor is necessary below the cooktop with integrated downdraft ventilation system. The drawers and/or shelves in the floor unit must be removable. The backpanel of the floor unit can be

Features

- kept - only a cut-out for the air outlet is needed (position and size can be taken from the installation instructions).
- An installation with unducted recirculation requires a vertical aperture of min. 25mm behind the backpanel of the furniture. Suggested for ideal performance are 50mm.
 - The minimum worktop thickness is 16 mm for top mounted and flush installed appliances with the standard installation system.
 - - The overall appliance weight is 26kg - the bearing capacity and stability, in the case of very thin worktops in particular, must be supported using suitable substructures. The overall appliance weight and the worktop manufacturer's structural integrity specifications are to be taken into account.
 - - For partly ducted and unducted recirculation extraction installations, a return-flow aperture of $\geq 400\text{cm}^2$ is to be respected in the plinth area. The aperture can be realized via outlet grids, lamella grids or subtly shortened plinths depending on the assortment of the kitchen furniture manufacturer.
 - - The air outlet on the backside of the appliance can directly be accessed with a male flat duct element (DN 150).
 - - The pressuredrop resistant blower allows longer and more complex ductings up to 8m with three 90° bows while keeping sufficient performance.
 - - When installing a ventilation hood with ducted extraction and a chimney-vented fireplace, the power supply line of the appliance needs a suitable safety switch. This is not required for configurations in recirculated extraction.
 - - In ducted extraction configuration a one-way flap (or backflow trap) with a maximum opening pressure of 65Pa should be installed.

iQ700, Induction hob with integrated ventilation system, 80 cm, Matt black, EX87BNX68E

Dimensioned drawings

measurements in mm

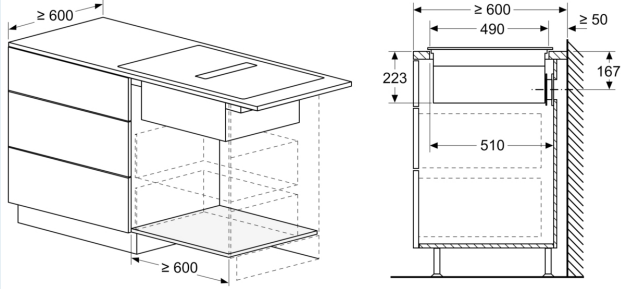

measurements in mm

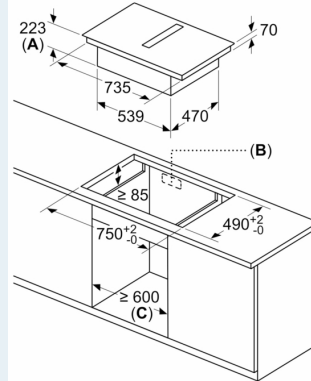

- A:** Recess depth
- B:** Cut-out in back panel required for pipework. Exact size and position can be taken from specific drawing.
- C:** All 80 cm width class models can be installed in 60 cm wide furniture by adjusting the side panels.

Measurements in mm

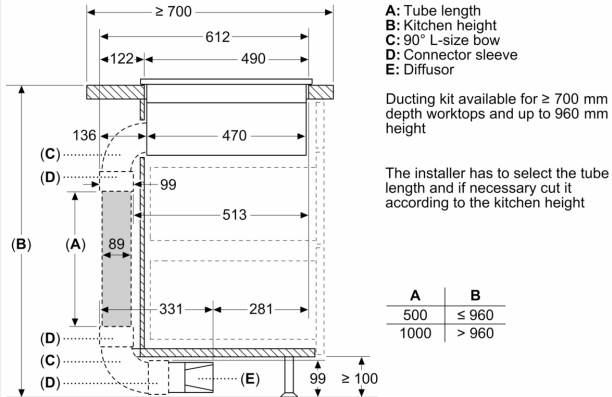

Measurements in mm

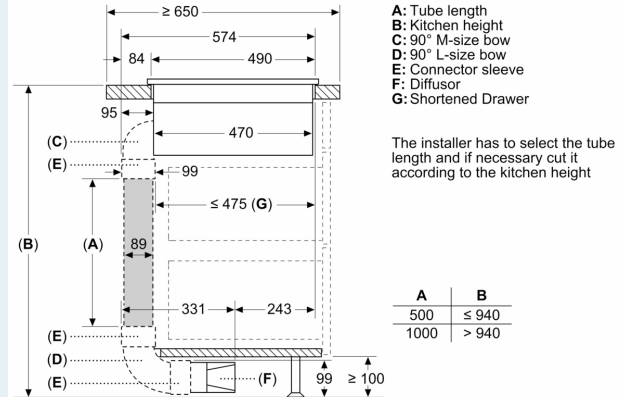

Dimensioned drawings

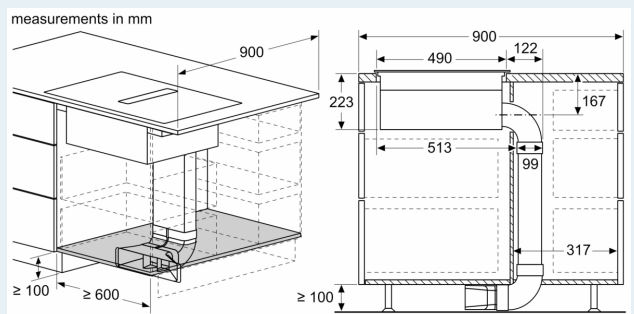
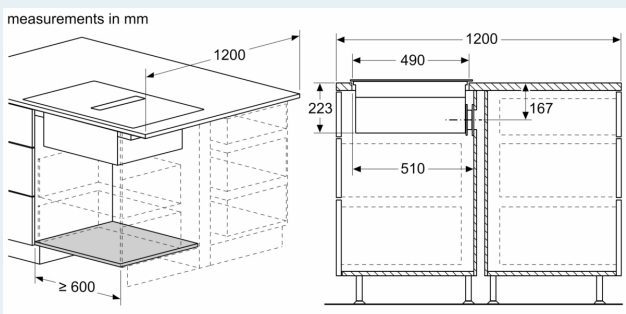
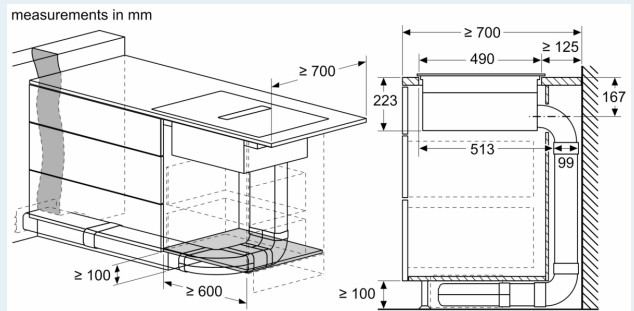
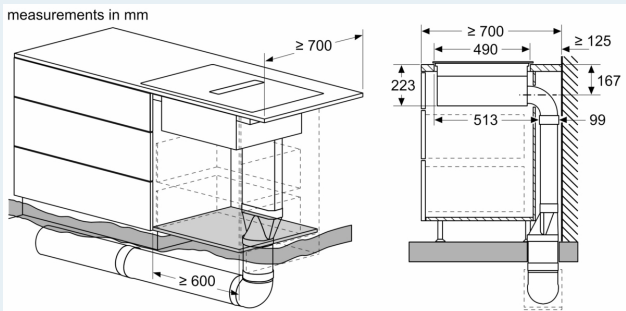
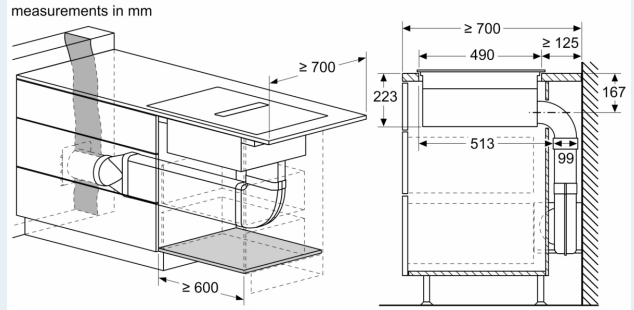
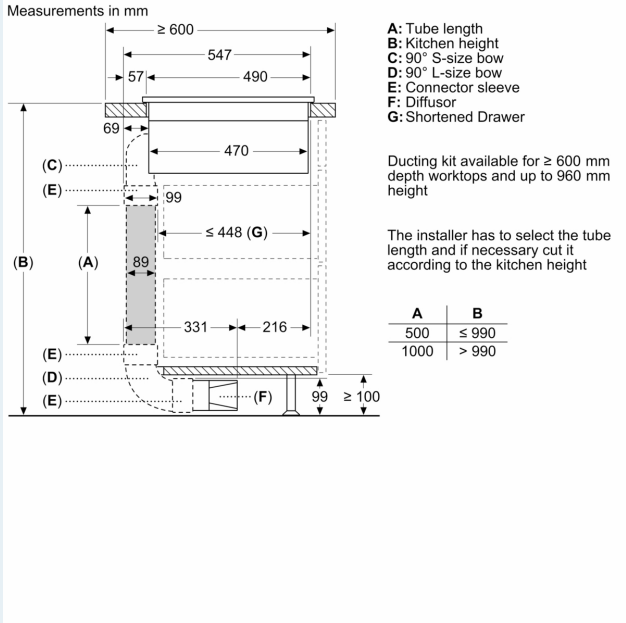

Dimensioned drawings

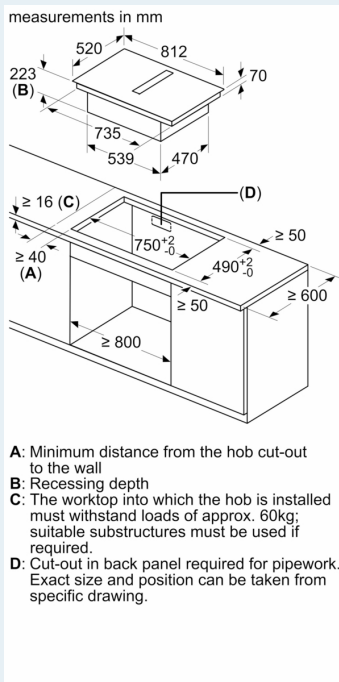
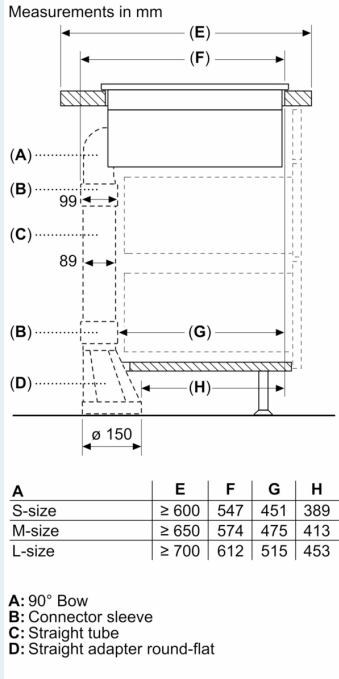

Measurements in mm

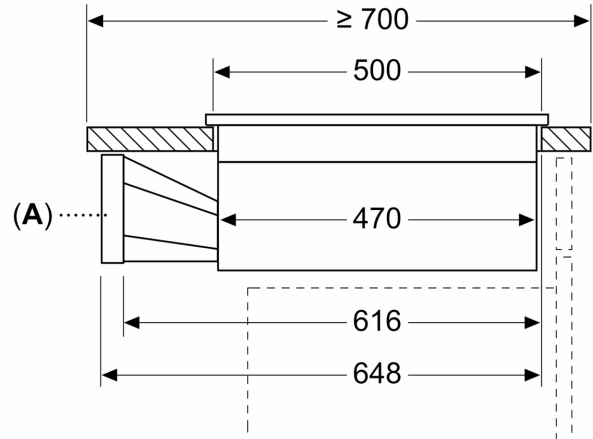

measurements in mm Front view

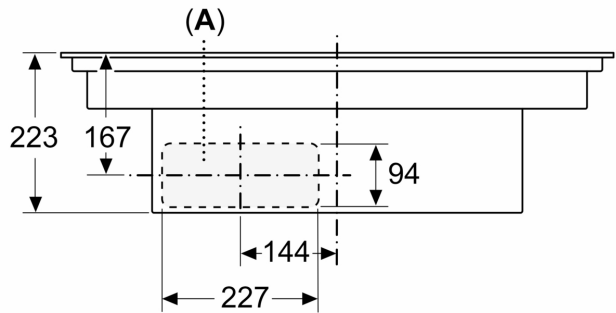

Dimensioned drawings

measurements in mm
Front view - unit cut-out
for unducted recirculation

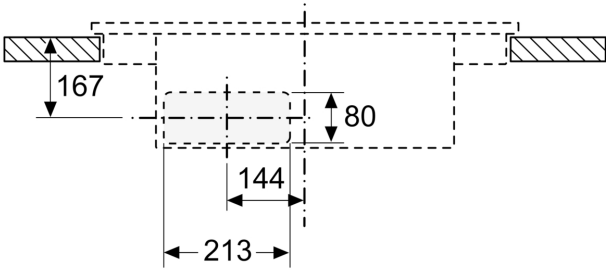

measurements in mm
Front view

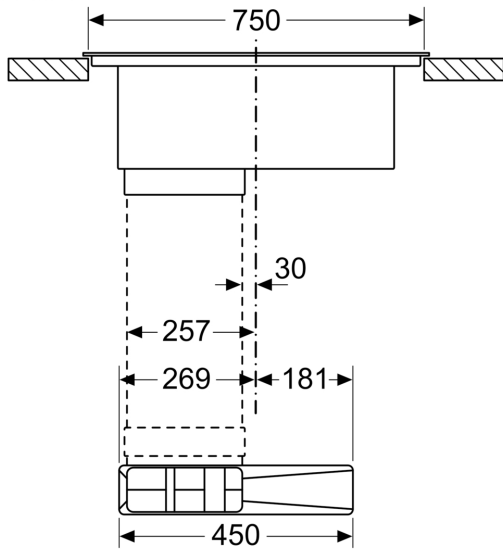

measurements in mm

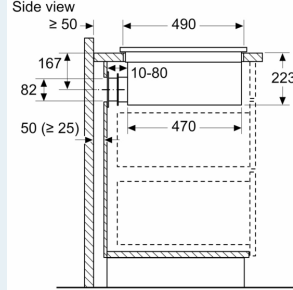

When installing directly against outer walls that are not insulated ($\mu \geq 0.5 \text{ W/m}^2 \cdot \text{C}$), we recommend using partially or fully ducted recirculation configurations.