

## iQ500, Induction hob with integrated ventilation system, 80 cm, surface mount without frame ED851FQ15E

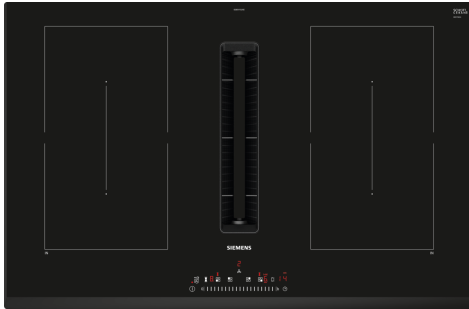

### Included accessories

1 x Slider for unducted recirculation, 1 x Clean Air Plus odor filter

### Optional accessories

HZ9SE040 4 pieces Set, HZ9SE060 6 pieces Set, HZ9VDKE1 Exhaust kit, HZ9VDKR0 Recirculation kit 2 L-bow (70cm), HZ9VDKR1 Recirculation kit S and L-bow (60cm), HZ9VDKR2 Recirculation kit 1x L-bow, HZ9VDSB1 90° flat duct bend horizontal, HZ9VDSB2 90° flat duct L vertical, HZ9VDSB3 90° flat duct M vertical, HZ9VDSB4 90° flat duct S vertical, HZ9VDSIO Adapter round-flat, HZ9VDSI1 90° Adapter round-flat, HZ9VDSM1 Straight tube 500mm, HZ9VDSM2 Straight tube 1000mm, HZ9VDS1 Connector sleeve (female), HZ9VDS2 Flexibel connecting piece DN 150 flat, HZ9VEDU0 Acoustics Filter, HZ9VRCR0 cleanAir recirculation replenishment fil, HZ9VRCR1 Clean Air Plus odor filter (replacement), HZ9VRPD1 Plinth Diffusor, HZ32WA00 Wireless food thermometer, HZ390090 Wok Set consisting of 3 Items, HZ390230 System pan diameter 21cm, HZ9ES100 Espresso maker 4 cups, HZ9FE280 Iron pan Ø 18 / 28 cm, HZ9SE030 Set of 2 pots and 1 pan

Design hob with a fully integrated, totally flush air-inlet.

- ✓ combiZone – Connect two induction zones together for large cookware.
- ✓ Allows to control the temperature by entering it directly or by moving the slider with a single finger - touchSlider Control.
- ✓ The inductionAir Plus guarantees minimal noise without compromising on suction power.
- ✓ Easy cleaning – Minimal cleaning effort for your built-in extractor.
- ✓ For convenient cooking thanks to preset power levels - powerMove.

### Features

#### Technical Data

Product name/family: ..... Cooking zone ceramic  
 Built-in / Free-standing: ..... Built-in  
 Source of energy: ..... Electric  
 Min. required niche size for installation (HxWxD): ..223 x 750-750 x 490-490 mm  
 Width of the appliance: ..... 802 mm  
 Dimensions: ..... 223 x 802 x 522 mm  
 Dimensions of the packed product (HxWxD): ... 431 x 970 x 672 mm  
 Weight: ..... 25.1 kg  
 Gross weight: ..... 31.5 kg  
 Residual heat indicator: ..... Separate  
 Location of control panel: ..... Front  
 Basic surface material: ..... Ceramic  
 Color of surface: ..... Black  
 Length electrical supply cord: ..... 110.0 cm  
 Sealed Burners: ..... No  
 heating with booster: ..... All  
 Power of 2nd heating element (kW): ..... 3.6 kW  
 Number of speed settings: ..... 9-stage + 2 intensive  
 Maximum output air extraction: ..... 500 m³/h  
 Boost position output recirculating: ..... 595.0 m³/h  
 Maximum output recirculating air: ..... 487 m³/h  
 Boost position air extraction: ..... 622 m³/h  
 Noise level: ..... 69 dB(A) re 1 pW  
 Odour filter: ..... No  
 Ventilation type: ..... Convertible  
 Nominal power: ..... 220-240/380-415 V  
 Frequency: ..... 50; 60 Hz  
 Included accessories: ..... 1 x Slider for unducted recirculation, 1 x Clean Air Plus odor filter  
 Delay Shut off modes: ..... 30R\_12E min



## iQ500, Induction hob with integrated ventilation system, 80 cm, surface mount without frame ED851FQ15E

### Features

#### Design

- 3 sided bevelled frameless finish
- 80 cm: space for 4 pots or pans.

#### Flexibility of cooking zones

- 2 Combi zones
- : use bigger cookware by connecting two classic cooking zones into one large zone.
- Cooking zone front left: 190 mm, 210 mm, 2.2 KW (max. power 3.7 KW)
- Cooking zone rear left: 190 mm, 210 mm, 2.2 KW (max. power 3.7 KW)
- Cooking zone rear right: 190 mm, 210 mm , 2.2 KW (max power 3.7 KW)
- Cooking zone front right: 190 mm, 210 mm, 2.2 KW (max. power 3.7 KW)

#### Usage convenience

- touchSlider control: directly control the power with the imprinted touch bar.
- 17 power levels: precisely adapt the heat with 17 power levels (9 main levels and 8 intermediate levels).
- Timer for all zones
- : switches off the cooking zone at the end of the time set (e.g. for boiled eggs).
- Acoustic signal
- : an alarm sounds at the end of the time set (e.g. for pasta).

#### Time saving & efficiency

- Power boost setting
- : boil water faster thanks to 50% more energy than at the highest standard level.
- 2-steps: increase or decrease the power level simply by moving the pot forwards or backwards.
- quickStart function: when switching on, the hob automatically selects the cooking zone with cookware (when placed on a zone whilst the hob is off).
- reStart function: in case of unintentional switch-off, this feature restores all previous settings by switching on the hob again within 4 seconds.

#### Safety

- 2 stage residual heat indicators: indicates which cooking zones are still hot or warm.
- Control panel lock: prevent unintended activation of the hob.
- Control panel pause: wipe overboiled liquids without unintentionally changing settings (blocking all touch buttons for 30 seconds).
- Main on/off switch: switch off all cooking zones at the touch of a button.
- Automatic safety switch off: for safety reasons, heating stops after a preset time if not used (possible to customise).
- Energy Consumption Display: shows the electricity consumption of

the last cooking process.

#### Installation

- Dimensions of the product (HxWxD mm): 223 x 802 x 522
- Required niche size for installation (HxWxD mm) : 223 x 750 x (490 - 490)
- Min. worktop thickness: 16 mm
- Connected load: 7.4 KW
- Connection current management (20, 16, 13, 10 Amps options): limit the maximum power if needed (depends on fuse protection of electric installation).
- HZ9VDKR1 for partly-ducted recirculation in worktops of  $\geq 60$ cm depth with max. worktop height of 960 mm. HZ9VDKR0 for partly-ducted recirculation in worktops of  $\geq 70$ cm depth with max. worktop height of 960 mm.
- HZ9VDKE1 as starter kit for ducted extraction in worktops of  $\geq 60$ cm depth.
- To complete the fully ducted extraction or to do any other individual recirculation planning different ducting accessories are available.

#### Integrated ventilation downdraft system

- Induction cooktop with fully integrated high-performance downdraft extractor.
- Aesthetically integrated fully flush air intake design with floating, heat resistant glass ceramics element for free movement and placement of cookware.
- Ventilation system with 9 electronically controlled fan power levels and 2 Boost-/Intensive fan power levels (with automatic revert) via touchSlider control user interface:
- - Automatic switch-on of ventilation system when a cooking zone is used.
- - Automatic delayed shut-off after cooking to erase residual odors after cooking (in specific ultra low-noise fan level, 12min in ducted extraction, 30min in recirculated extraction, can be shut-off manually).
- - Fully manual control possible via touchSlider control.
- High-performance, low-noise blower with energy-efficient BLDC-technology. High extraction rates at very low noises with pleasant noise frequencies through psycho-acoustically and aerodynamically optimized interior with enclosed, non-visible blower. Highly pressuredrop resistant even with longer and more complex ductings.
- Easy-to-detach and easy-to-clean grease filter and liquid collector unit:
- - Convenient one-hand removal of unit via floating glass ceramics handle.
- - Integrated, large-scale, high performance stainless-steel grease filters with 12 filtration layers and one black top layer for enhanced aesthetical integration. Grease filtration efficiency of 94 %.
- - All parts of the unit are easy-to-clean, fully dishwasher safe and heat resistant.
- - (Upper) Liquid collector unit with 200ml of capacity for standard accidental spillages or cooking condensate.

## Features

- - Powerful drainage system for spillages that exceed 200ml of liquids.
- - Liquid safety collector with additional capacity of 700ml for more severe accidental situations. Dishwasher safe. Easily accessible and detachable from below.
- - Overall capturing capacity of 900ml (200ml + 700ml).
- - Watertight blower system.
- Ventilation system performance:
  - - Extraction performance in ducted extraction (according to EN 61591): min. normal setting 154 m<sup>3</sup>/h , max. normal setting 500 m<sup>3</sup>/h , max. Boost-/Intensive setting 622 m<sup>3</sup>/h .
  - - Extraction performance in recirculated extraction (according to EN 61591): min. normal setting 117 m<sup>3</sup>/h , max. normal setting 487 m<sup>3</sup>/h , max. Boost-/Intensive setting 595 m<sup>3</sup>/h.
  - - Noise level in ducted extraction (Sound power level according to EN 60704-3): min. normal setting 42 dB re 1 pW, max. normal setting 69 dB re 1 pW, max. Boost-/Intensive setting 74 dB re 1 pW.
  - - Noise level in recirculated extraction (Sound power level according to EN 60704-3. ): min. normal setting 41 dB re 1 pW, max. normal setting 68 dB re 1 pW, max. Boost-/Intensive setting 72 dB re 1 pW.
  - - Grease filter efficiency (according to EN 61591) 94 %.
  - Consumption data and energy efficiency (according to Regulation (EU) No 65/2014):
    - - Energy Efficiency Class: B (at a range of energy efficiency classes from A+++ to D).
    - - Fluid Dynamic Efficiency: A .
    - - Average energy consumption: 57 .
    - - Grease filtration efficiency class: B .
  - - Noise min. normal setting & max. normal setting: 42 dB & 69 dB .
  - - Optimised odour reduction performance for cooking applications with complex odour molecules (e.g. fish).
  - - Large scale filter surface with high odour reduction capabilities.
  - - Lifetime of 360 hours of cooking (non-regenerative).
  - - Low-noise filters with optimised psycho-acoustics.
  - - Easy-to-access and easy-to-remove from above.
  - - Replenishment cleanAir filter set HZ9VRCR0.
  - For ducted extraction configuration: 2 x 2 sets of directly integrated, high-performance low-noise acoustic filters for significantly lower noise and improved psycho-acoustics.

### Planning & installation notes

- - Installation is possible in island as well as wall oriented configurations.
- The product and its accessories comply with the Needle Flame Test (according to IEC 60695-11-5) and the V2 flammability class (according to UL94).
- - The max. immersion depth is 223 mm below worktop surface.
- - The appliance must be freely accessible from below (i.e. for accessing the lower liquid safety collector).
- - No false floor is necessary below the cooktop with integrated downdraft ventilation system. The drawers and/or shelves in the floor unit must be removable. The backpanel of the floor unit can be kept - only a cut-out for the air outlet is needed (position and size can be taken from the installation instructions).
- An installation with unducted recirculation requires a vertical aperture of min. 25mm behind the backpanel of the furniture. Suggested for ideal performance are 50mm.
- The minimum worktop thickness is 16 mm for top mounted and flush installed appliances with the standard installation system.

Installation in even thinner worktops is also possible with the spare part: content 626792.

- - The overall appliance weight is 26kg - the bearing capacity and stability, in the case of very thin worktops in particular, must be supported using suitable substructures. The overall appliance weight and the worktop manufacturer's structural integrity specifications are to be taken into account.
- - For partly ducted and unducted recirculation extraction installations, a return-flow aperture of  $\geq 400\text{cm}^2$  is to be respected in the plinth area. The aperture can be realized via outlet grids, lamella grids or subtly shortened plinths depending on the assortment of the kitchen furniture manufacturer.
- - The air outlet on the backside of the appliance can directly be accessed with a male flat duct element (DN 150).
- - The pressuredrop resistant blower allows longer and more complex ductings up to 8m with three 90° bows while keeping sufficient performance.
- - When installing a ventilation hood with ducted extraction and a chimney-vented fireplace, the power supply line of the appliance needs a suitable safety switch. This is not required for configurations in recirculated extraction.
- - In ducted extraction configuration a one-way flap (or backflow trap) with a maximum opening pressure of 65Pa should be installed.

## iQ500, Induction hob with integrated ventilation system, 80 cm, surface mount without frame ED851FQ15E

### Dimensioned drawings

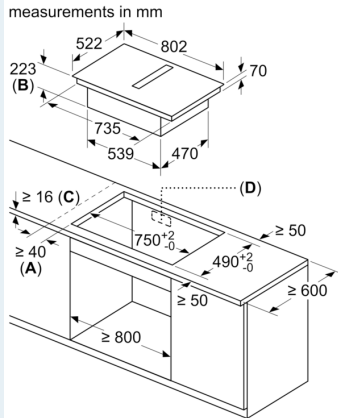

- A:** Minimum distance from the hob cut-out to the wall
- B:** Recessing depth
- C:** The worktop into which the hob is installed must withstand loads of approx. 60kg; suitable substructures must be used if required.
- D:** Cut-out in back panel required for pipework. Exact size and position can be taken from specific drawing.

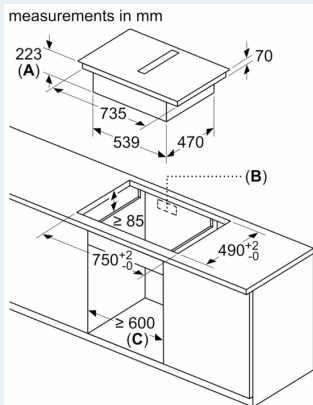

- A:** Recess depth
- B:** Cut-out in back panel required for pipework. Exact size and position can be taken from specific drawing.
- C:** All 80 cm width class models can be installed in 60 cm wide furniture by adjusting the side panels.

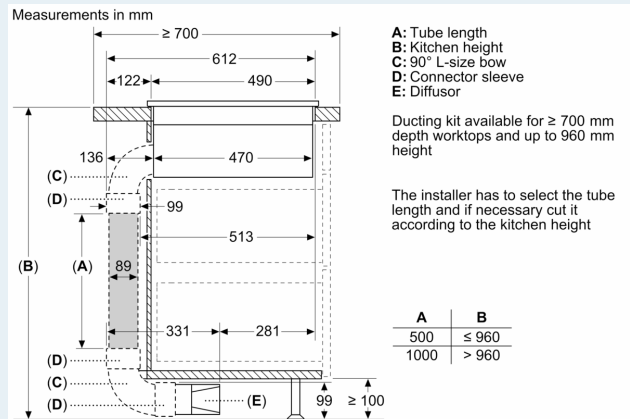
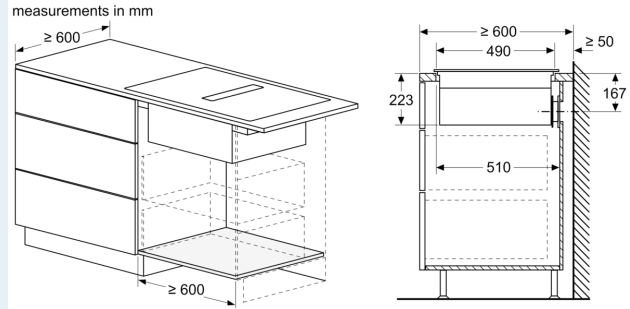

- A:** Tube length
- B:** Kitchen height
- C:** 90° L-size bow
- D:** Connector sleeve
- E:** Diffuser

Ducting kit available for ≥ 700 mm depth worktops and up to 960 mm height

The installer has to select the tube length and if necessary cut it according to the kitchen height

## Dimensioned drawings

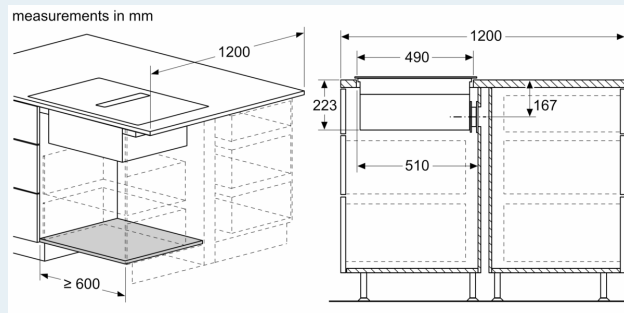
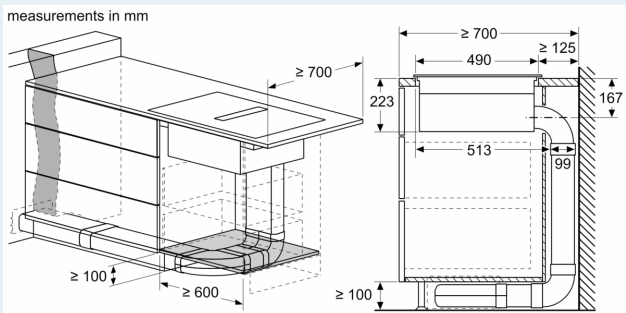
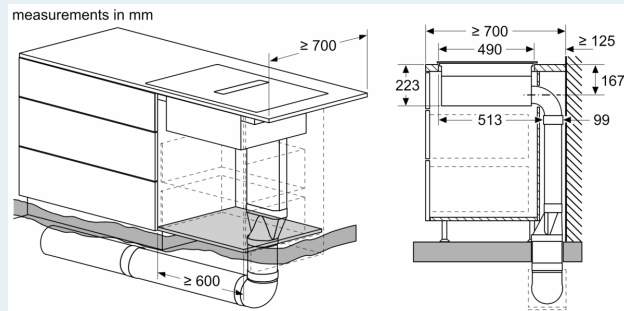
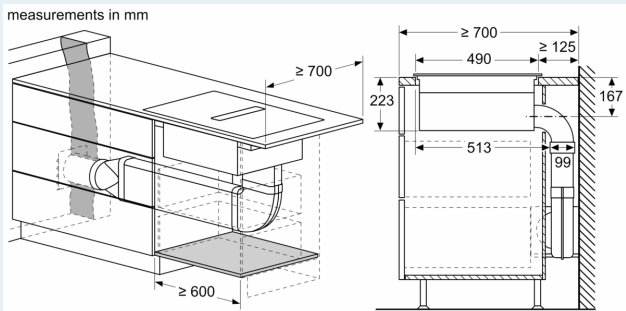
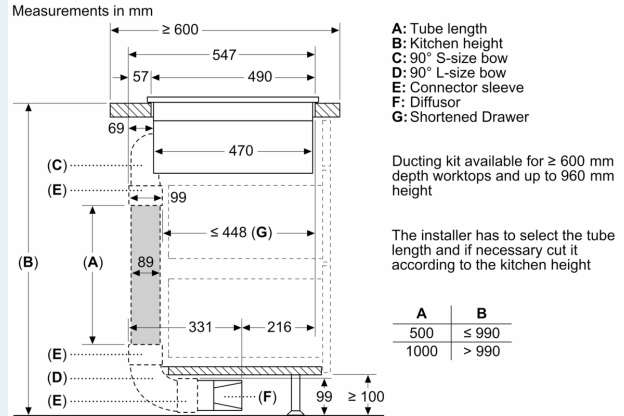
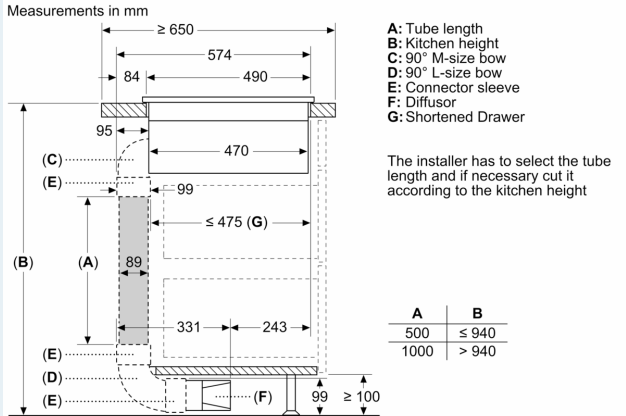



## Dimensioned drawings

measurements in mm  
Front view

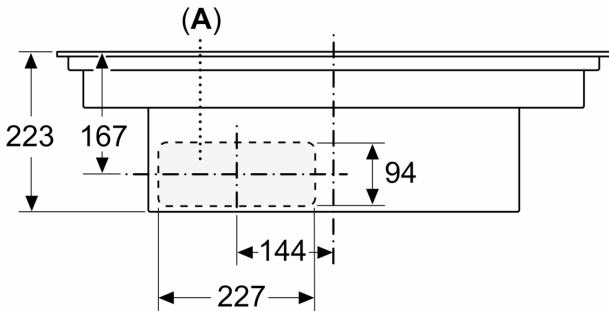

**A:** Connected directly at the rear

measurements in mm  
Front view - unit cut-out  
for unducted recirculation

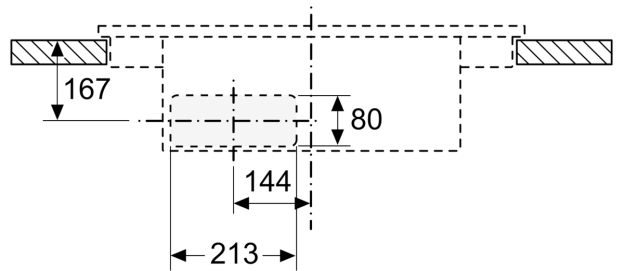

measurements in mm  
Side view

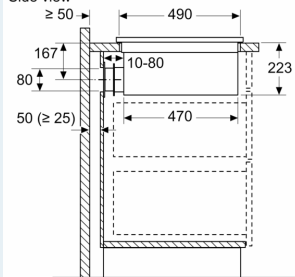

When installing directly against outer walls that are not insulated ( $\mu \geq 0.5 \text{ W/m}^2\text{°C}$ ), we recommend using partially or fully ducted recirculation configurations.

measurements in mm  
Front view

