

**Series 2, Wall-mounted cooker hood,
90 cm, Stainless steel
DWP94BC50B**



DHZ1224	Chimney extension 500 mm
DHZ1234	Chimney extension 750 mm
DHZ5275	Standard recirculation kit
DHZ5276	Standard odor filter (replacement)
DHZ9550	Brushed steel back panel
DHZ9551	Brushed steel back panel

**Pyramid hood: perfect performance
matching your kitchen.**

- **LED Illumination:** The energy-saving lighting provides bright and clear lighting for the hob area.
- **High extraction rate - for continuously clean air in the kitchen.**
- **3-speed power Level options to suit your cooking style and recipes.**
- **Dishwasher safe aluminum mesh filters**

Typology:	Wall-mounted
Length electrical supply cord:	130.0 cm
Height of the chimney:	553-730/573-730 mm
Height of the appliance:	246 mm
Minimum distance above an electric hob:	550 mm
Minimum distance above a gas hob:	650 mm
Net weight:	10.7 kg
Type of control:	mechanical
Number of speed settings:	3
Max. air extraction:	365 m ³ /h
Max. air recirculation:	213 m ³ /h
Maximum Air flow:	365 m ³ /h
Number of lights:	2
Noise level:	65 dB(A) re 1pW
Diameter of air outlet:	120 / 150 mm
Grease filter material:	Washable aluminium
EAN code:	4242005032020
Connection rating:	100 W
Fuse protection:	10 A
Voltage:	220-240 V
Frequency:	50; 60 Hz
Plug type:	GB plug
Installation typology:	Wall-mounted



Series 2, Wall-mounted cooker hood, 90 cm, Stainless steel DWP94BC50B

Pyramid hood: perfect performance matching your kitchen.

Key performance features:

- Energy Efficiency Class: D (at a range of energy efficiency classes from A+++ to D)
- Max. extraction rate: 365 m³/h
- Noise max. Normal Level: Noise, max. speed in normal us: 65 dB dB*

Features

- Push button control
- 3 power levels
- 2 x 1.5W LED light
- Colour Temperature: 3500 K
- 3 removable metal grease filter cassettes
- Installation: wall

Design

- Chimney extractor hood
- Mechanical

Performance/technical information

- Suitable for ducted or recirculating operation
- For recirculated extraction recirculating kit (accessory) needed
- Maximum extraction rate exhaust air 365 m³/h according to EN 61591
- Extraction rate in recirculation mode:
 - Max. normal use: 213 m³/h
- Noise level according to EN 60704-3 and EN 60704-2-13 at max. normal use exhaust air: 65 dB(A) re 1 pW
- Noise level in recirculation mode:
 - Max. normal use: 67 dB(A) re 1 pW (54 dB(A) re 20 µPa sound pressure)
- Power rating: 100 W
- Light Intensity: 94 lux
- Electrical cable length 1.3 m
- Diameter pipe Ø 150 mm (Ø 120 mm enclosed)
- Dimensions exhaust air (HxWxD): 799-975 x 900 x 500 mm
- Dimensions recirculating (HxWxD): 799-975 x 900 x 500 mm
- Blower Efficiency Class: E*
- Lighting Efficiency Class: A*
- Grease Filtering Efficiency Class: D*
- Average Energy Consumption: 53.1 kWh/year*

Optional accessories

- Recirculating kit DHZ1224

* In accordance with the EU-Regulation No 65/2014

**Series 2, Wall-mounted cooker hood,
90 cm, Stainless steel
DWP94BC50B**

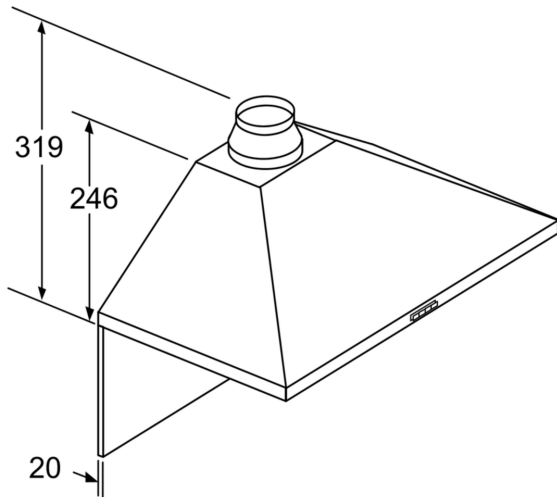

If a back panel is used,
the design of the appliance
must be considered.

measurements in mm

Measurements in mm

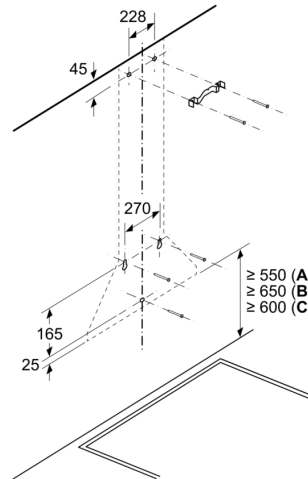

A: Electric

B: Gas - from upper edge of pan support

C: Electric - for Australia and New Zealand

Measurements in mm

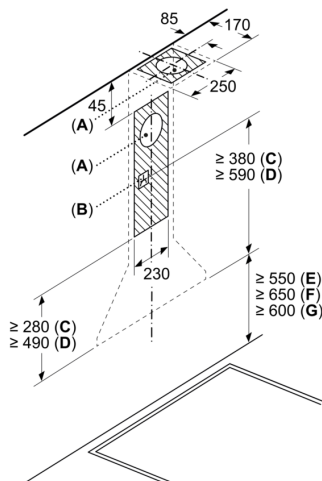

A: Exhaust-air outlet

B: Socket

C: Exhaust air

D: Circulated air

E: Electric

F: Gas - from upper edge of pan support

G: Electric - for Australia and New Zealand

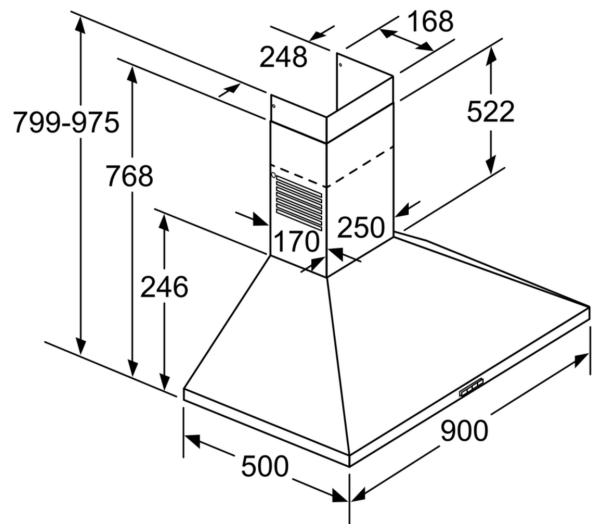

measurements in mm