

**Series 4, Built-under cooker hood, 60 cm, Stainless steel  
DUL63CC50B**



DHZ2701 Standard odor filter

**Conventional cooker hoods are mounted under cabinets and always visible, allowing you to keep your storage space.**

- **LED Illumination:** The energy-saving lighting provides bright and clear lighting for the hob area.
- **High extraction rate - for continuously clean air in the kitchen.**
- **Adjust the extraction intensity according to your cooking needs.**
- **Dishwasher safe aluminum mesh filters**
- **Ducted or Non-ducted Options**

Typology: .....	Built-in/Built-under
Length electrical supply cord: .....	145.0 cm
Height of the appliance: .....	150 mm
Minimum distance above an electric hob: .....	650 mm
Minimum distance above a gas hob: .....	650 mm
Net weight: .....	6.2 kg
Type of control: .....	mechanical
Number of speed settings: .....	3
Max. air extraction: .....	350 m <sup>3</sup> /h
Max. air recirculation: .....	110 m <sup>3</sup> /h
Maximum Air flow: .....	350 m <sup>3</sup> /h
Number of lights: .....	2
Noise level: .....	72 dB(A) re 1pW
Diameter of air outlet: .....	120 / 100 mm
Grease filter material: .....	Washable aluminium
EAN code: .....	4242002968513
Connection rating: .....	146 W
Voltage: .....	220-240 V
Frequency: .....	50 Hz
Plug type: .....	GB plug
Installation typology: .....	Built-under



## **Series 4, Built-under cooker hood, 60 cm, Stainless steel DUL63CC50B**

**Conventional cooker hoods are mounted under cabinets and always visible, allowing you to keep your storage space.**

### **Key performance features:**

- Energy Efficiency Class: D (at a range of energy efficiency classes from A+++ to D)
- Maximum extraction 350 m<sup>3</sup>/h
- Noise max. Normal Level: Noise, max. speed in normal us: 72 dB dB\*

### **Features**

- Push button control for extractor speeds and light
- 3 power levels
- 2 x 4W LED light
- Colour Temperature: 3000 K
- 2 removable metal grease filter cassettes

### **Design**

- Built under conventional hood
- Installation: Wall or under hang-up cupboard
- Adjustable glass visor
- Push button control
- Mechanical

### **Performance/technical information**

- Suitable for ducted or recirculating operation
- For recirculated extraction charcoal filter (accessory) needed
- Noise level according to EN 60704-3 and EN 60704-2-13 at maximum normal setting: extraction rate: 72 dB (A) re 1pW
- Power rating: 146 W
- Light Intensity: 45 lux
- Electrical cable length 1.45 m
- Blower Efficiency Class: E\*
- Lighting Efficiency Class: E\*
- Grease Filtering Efficiency Class: C\*
- Average Energy Consumption: 93.3 kWh/year\*
- Diameter pipe Ø 120 mm (Ø 100 mm enclosed)
- Dimensions exhaust air (HxWxD): 150-150 x 600 x 482 mm
- Dimensions recirculating (HxWxD): 150-150 x 600 x 482 mm

### **Optional accessories**

- Recirculating kit DHZ2701

\* In accordance with the EU-Regulation No 65/2014

**Series 4, Built-under cooker hood, 60  
cm, Stainless steel  
DUL63CC50B**

---

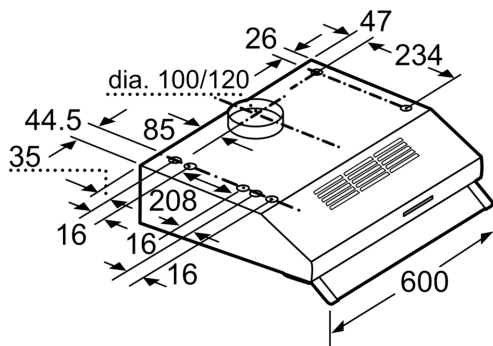

measurements in mm