

**Series 6, Ceiling cooker hood, 90 cm,
Stainless steel
DRC97AQ50B**



The integrated ceiling hood: the powerful and effective solution for larger and open plan kitchens, perfectly installed directly into the ceiling.

- **Especially silent:** maximum hood performance, minimum noise.
- **Easy-to-clean interior:** hidden screws and cables along with rounded edges make cleaning easy.
- **Manage your appliances with your voice, thanks to the Amazon Alexa voice control.***
- **Cooktop-based hood control: use the hob to control your hood.**
- **Home Connect: hoods with smart connectivity make life easier.**

DIZ1JC2C6	Clean Air Plus recirc.kit external white
DIZ1JC5C6	Clean Air Plus recirc. kit external inox
DZZ0XX0P0	Long Life odor filter (replacement)
DZZ1XX1B6	Clean Air Plus odor filter (replacement)
DIZ0JC2D0	Long Life recirc. kit external white
DIZ0JC5D0	Long Life recirc. kit external inox

Typology:Island/Ceiling
 Length electrical supply cord: 130.0 cm
 Min. required niche size for installation (HxWxD): 299mm x 888.0mm x 487mm mm
 Minimum distance above an electric hob: 650 mm
 Minimum distance above a gas hob:650 mm
 Net weight: 22.2 kg
 Type of control:Electronic
 Number of speed settings:3-stage + 2 intensive
 Max. air extraction: 459 m³/h
 Boost position output recirculating:565.0 m³/h
 Max. air recirculation: 422 m³/h
 Boost position air extraction: 798 m³/h
 Maximum Air flow:459 m³/h
 Number of lights: 4
 Noise level:56 dB(A) re 1pW
 Diameter of air outlet: 150 mm
 Grease filter material: Washable stainless steel
 EAN code:4242005103997
 Connection rating: 174 W
 Voltage: 220-240 V
 Frequency: 50; 60 Hz
 Plug type:GB plug
 Installation typology: Island



Series 6, Ceiling cooker hood, 90 cm, Stainless steel DRC97AQ50B

The integrated ceiling hood: the powerful and effective solution for larger and open plan kitchens, perfectly installed directly into the ceiling.

Key performance features:

- Energy Efficiency Class: A (at a range of energy efficiency classes from A+++ to D)
- Extraction rate according to EN 61591 ø 15 cm:
- max. Normal use: 458 m³/h
- Intensive: 798 m³/h
- Noise max. Normal Level: Noise, max. speed in normal use: 56 dB dB*

Home Connect: Remote Monitoring and Control

- Home Connect: Remote Monitoring and Control for connected home appliances and operation via smartphone or tablet (only in countries where Home Connect service is available)
- The Home Connect functionality can be extended by integrating numerous applications from external cooperation partners (partnerships)
- Voice Control enabled via popular voice assistants (only in countries where this service is available)
- Interval function: available via Home Connect
- Silence function: available via Home Connect

Special features

- Hob based hood control
- Electronic display
- Infrared remote control
- 3 power levels and 2 intensive settings
- 4 x 3W LED lights
- Colour Temperature: 3500 K
- Dimmer function
- Interval operation
- Automatic intensive revert (6mins)
- Automatic after running (Automatic after running (10 min))
- 2 removable metal grease filter cassettes
- Saturation indicator for metal and charcoal filter
- easy to clean Inner frame
- Rim ventilation

Design

- Installation: Ceiling
- Electronic control
- Efficient BLDC technology
- Rotatable motor: possible to position the air outlet on all four sides

Performance/technical information

- Suitable for ducted or recirculating operation
- For recirculated extraction CleanAir recirculating kit (accessory) needed
- Extraction rate according to EN 61591 max. 798 m³/h
- Noise level according to EN 60704-3 and EN 60704-2-13 at max.

- normal use exhaust air: 56 dB(A) re 1 pW
- Noise level according to EN 60704-3 and EN 60704-2-13 exhaust air:
- Max. normal use: 56 dB(A) re 1 pW
- Intensive: 68 dB(A) re 1 pW
- Noise level according to EN 60704-3 and EN 60704-2-13 at maximum normal setting: extraction rate: 56 dB (A) re 1pW
- With the Clean Air Plus recirculation kit (available as optional accessory) your appliances reaches:
- Extraction rate in recirculation mode: Max. normal use: 422 m³/h
- Intensive: 565 m³/h
- Noise level in recirculation mode with Clean Air Plus odor filter : Max. normal use: 63 dB(A) re 1 pW
- Intensive: 69 dB(A) re 1 pW
- Power rating: 174 W
- Light Intensity: 659 lux
- Electrical cable length 1.3 m
- Diameter pipe ø 150 mm (ø 150 mm enclosed)
- Dimensions exhaust air (HxWxD): 300-300 x 900 x 500 mm
- Dimensions recirculating (HxWxD): 300-300 x 900 x 500 mm
- Blower Efficiency Class: A*
- Lighting Efficiency Class: A*
- Grease Filtering Efficiency Class: E*
- Average Energy Consumption: 34 kWh/year*

Optional accessories

- Recirculating kit DIZ1JC2C6

* In accordance with the EU-Regulation No 65/2014

**Series 6, Ceiling cooker hood, 90 cm,
Stainless steel
DRC97AQ50B**

The fan outlet can be turned
in all four directions

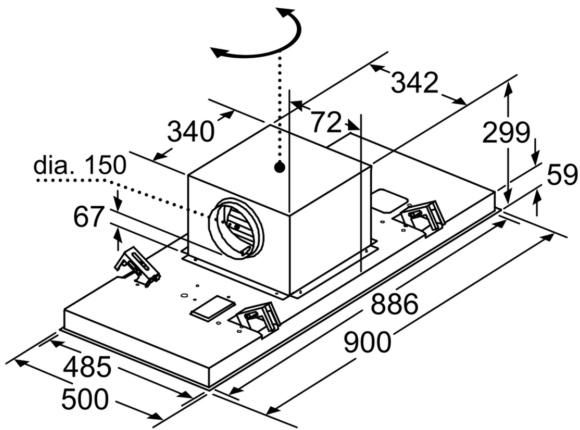

measurements in mm

measurements in mm
Air extraction

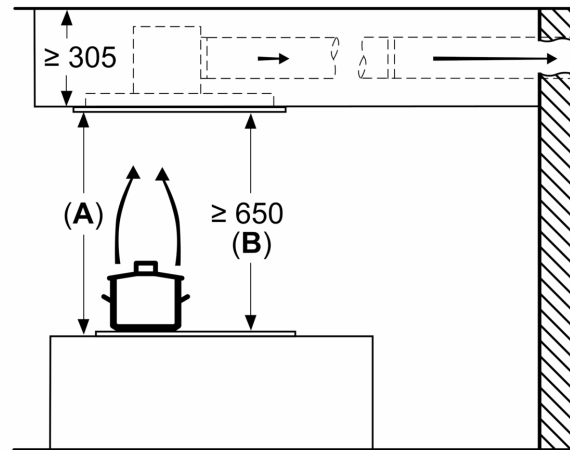

A: Optimum performance 700-1500
B: From upper edge of pan support

measurements in mm
Air recirculation

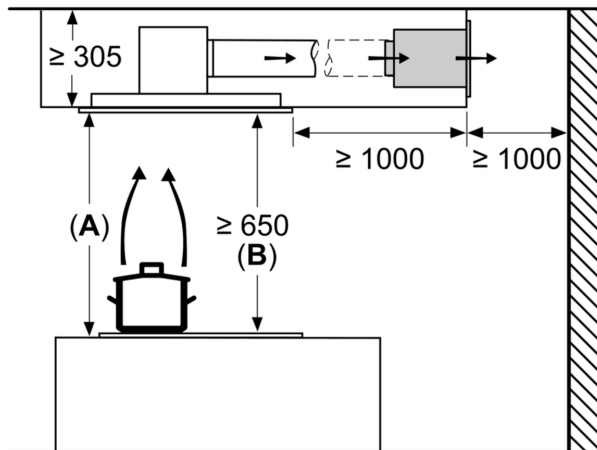

A: Optimum performance 700-1500
B: From upper edge of pan support

measurements in mm
Air recirculation

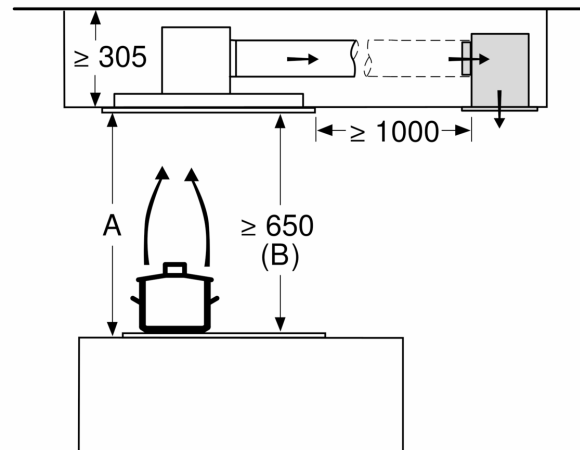

A: Optimum performance 700-1500
B: From upper edge of pan support

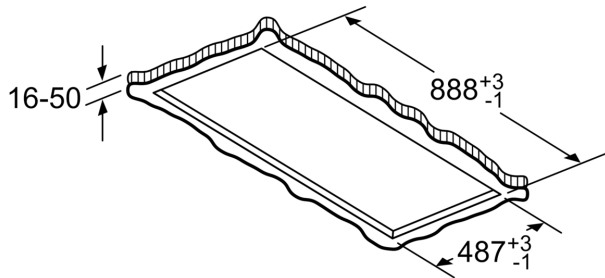

Never fit directly onto plasterboard or similar lightweight construction materials of the suspended ceiling. A suitable substructure is required that is securely fixed to the concrete ceiling.

measurements in mm