

Series 4, Telescopic cooker hood, 90 cm, Silver metallic DFS097A51B



DSZ4920	Installation kit for 90cm wide wall unit
DSZ4961	Lowering frame
DSZ4982	Handle strip white
DSZ4986	Handle strip black
DWZ0IT0P0	Long Life odor filter (replacement)
DWZ1IT1D1	Long Life recirculation kit external
DWZ1IX1B6	Clean Air Plus odor filter (replacement)
DWZ1IX1C6	Clean Air Plus recirc. kit external
DWZ2IT1B4	Clean Air Standard odor filter (repl.)
DWZ2IT1I4	Clean Air Standard recirculation kit

Telescopic cooker hoods extend when in use and slide neatly away when not in operation.

- **EcoSilence Drive™**: the powerful, energy-saving drive for hoods.
- **High extraction rate - for continuously clean air in the kitchen.**
- **Intensive Setting**: the powerful way to beat intense steam during cooking.
- **Enjoy the benefits of a cleaner and healthier kitchen, free from excessive grease and unwanted odors.**
- **LED Illumination**: The energy-saving lighting provides bright and clear lighting for the hob area.

Typology: Pull-out
 Length electrical supply cord: 175.0 cm
 Min. required niche size for installation (HxWxD): 385mm x 524.0mm x 290mm mm
 Height of the appliance: 426 mm
 Minimum distance above an electric hob: 430 mm
 Minimum distance above a gas hob: 650 mm
 Net weight: 12.5 kg
 Type of control: Electronic
 Number of speed settings: 3-stages + intensive setting
 Max. air extraction: 397 m³/h
 Boost position output recirculating: 628 m³/h
 Max. air recirculation: 358 m³/h
 Boost position air extraction: 729 m³/h
 Maximum Air flow: 397 m³/h
 Number of lights: 3
 Noise level: 53 dB(A) re 1pW
 Diameter of air outlet: 120 / 150 mm
 Grease filter material: Washable stainless steel
 EAN code: 4242005232109
 Connection rating: 146 W
 Fuse protection: 10 A
 Voltage: 220-240 V
 Frequency: 50; 60 Hz
 Plug type: GB plug
 Installation typology: Built-in



4 242005 232109

Series 4, Telescopic cooker hood, 90 cm, Silver metallic DFS097A51B

- Diameter pipe Ø 150 mm (Ø 120 mm enclosed)
- Electrical cable length 1.75 m

* In accordance with the EU-Regulation No 65/2014

Telescopic cooker hoods extend when in use and slide neatly away when not in operation.

Features

- Electronic control via Soft touch button control
- 3 power levels & intensive setting
- 3 x 1,5W LED
- Efficient BLDC technology
- Automatic intensive revert (6mins)
- Automatic after running (Automatic after running (10 min))
- 3 removable metal grease filter cassettes

Design

- 90 cm wide
- Silver metallic lacquer
- Handle strip specification: stainless steel with logo
- Steel filter cover

Performance

- Suitable for ducted or recirculating operation
- For recirculated extraction recirculating kit or CleanAir recirculating kit (accessory) needed
- Energy Efficiency Class: A (at a range of energy efficiency classes from A+++ to D)
- Extraction rate according to EN 61591 max. 729 m³/h
- Extraction rate according to EN 61591 ø 15 cm:
 - max. Normal use: 397 m³/h
 - Intensive: 729 m³/h
- Noise level according to EN 60704-3 and EN 60704-2-13 at max. normal use exhaust air: 53 dB(A) re 1 pW
- Noise level according to EN 60704-3 and EN 60704-2-13 exhaust air:
 - Max. normal use: 53 dB(A) re 1 pW
 - Intensive: 69 dB(A) re 1 pW
- With the Clean Air Plus recirculation kit (available as optional accessory) your appliances reaches:
 - Extraction rate in recirculation mode: Max. normal use: 358 m³/h
 - Intensive: 628 m³/h
 - Noise level in recirculation mode: Max. normal use: 60 dB(A) re 1 pW
 - Intensive: 71 dB(A) re 1 pW
- Colour Temperature: 3500 K
- Light Intensity: 355 lux
- Power rating: 146 W
- Average Energy Consumption: 38.1 kWh/year*
- Blower Efficiency Class: B*
- Lighting Efficiency Class: A*
- Grease Filtering Efficiency Class: B*

Planning and installation information

- Installation system: Telescopic comfort installat.
- Dimensions (HxWxD): 426 x 898 x 290 mm
- Built-in dimensions (HxWxD): 385 x 524 x 290 mm

Series 4, Telescopic cooker hood, 90 cm, Silver metallic DFS097A51B

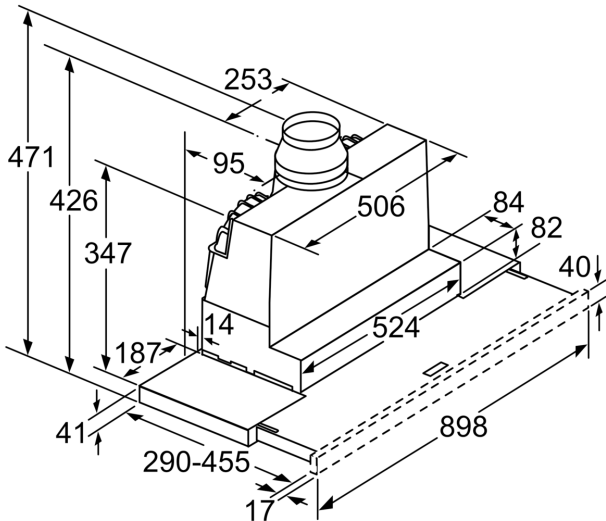

Depth of the filter drawer can be adjusted by up to 29 mm

measurements in mm

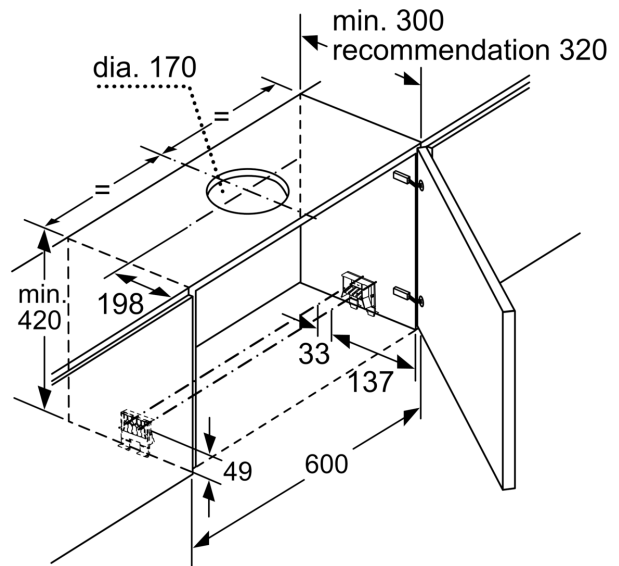

measurements in mm

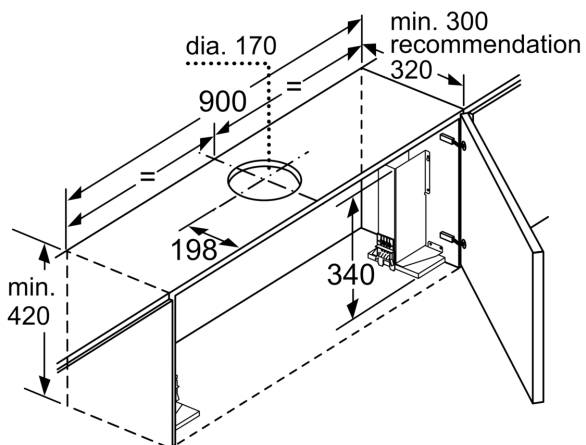

When installing the 90 cm telescopic hood in a 90 cm wide wall-hanging cupboard, a mounting kit is required. The two mounting brackets are screwed onto the left and right of the kitchen unit. Installation in accordance with template.

measurements in mm

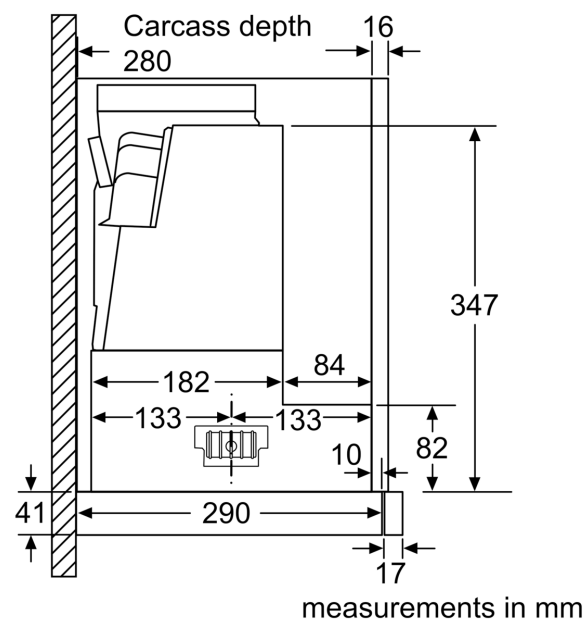

measurements in mm

